

A 10GE Monitoring System

Ariën Vijn
ariën@ams-ix.net

Agenda

- Introduction

The role of an internet exchange (IX).

- The problem to be solved.

Real life examples

- The chosen solution for that problem

- * The Force10's P10 IDS/IPS card

- * Photonic cross connects

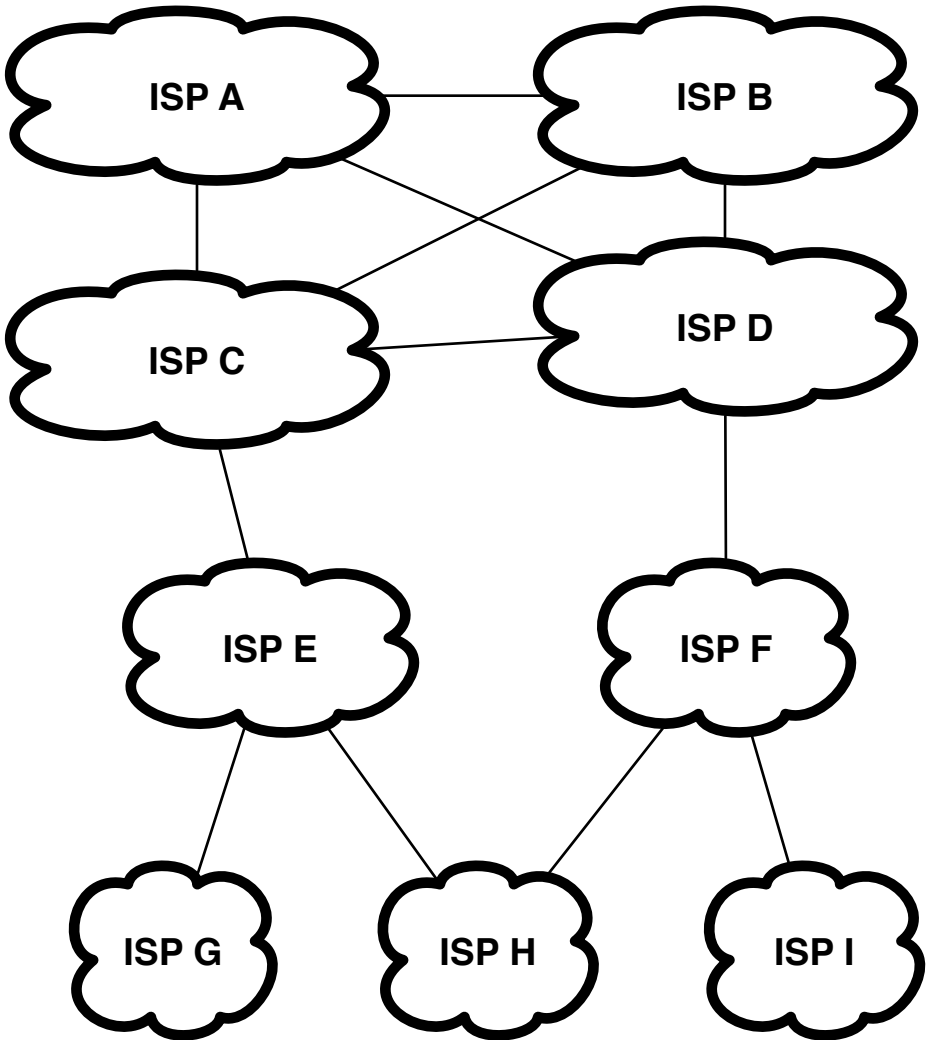

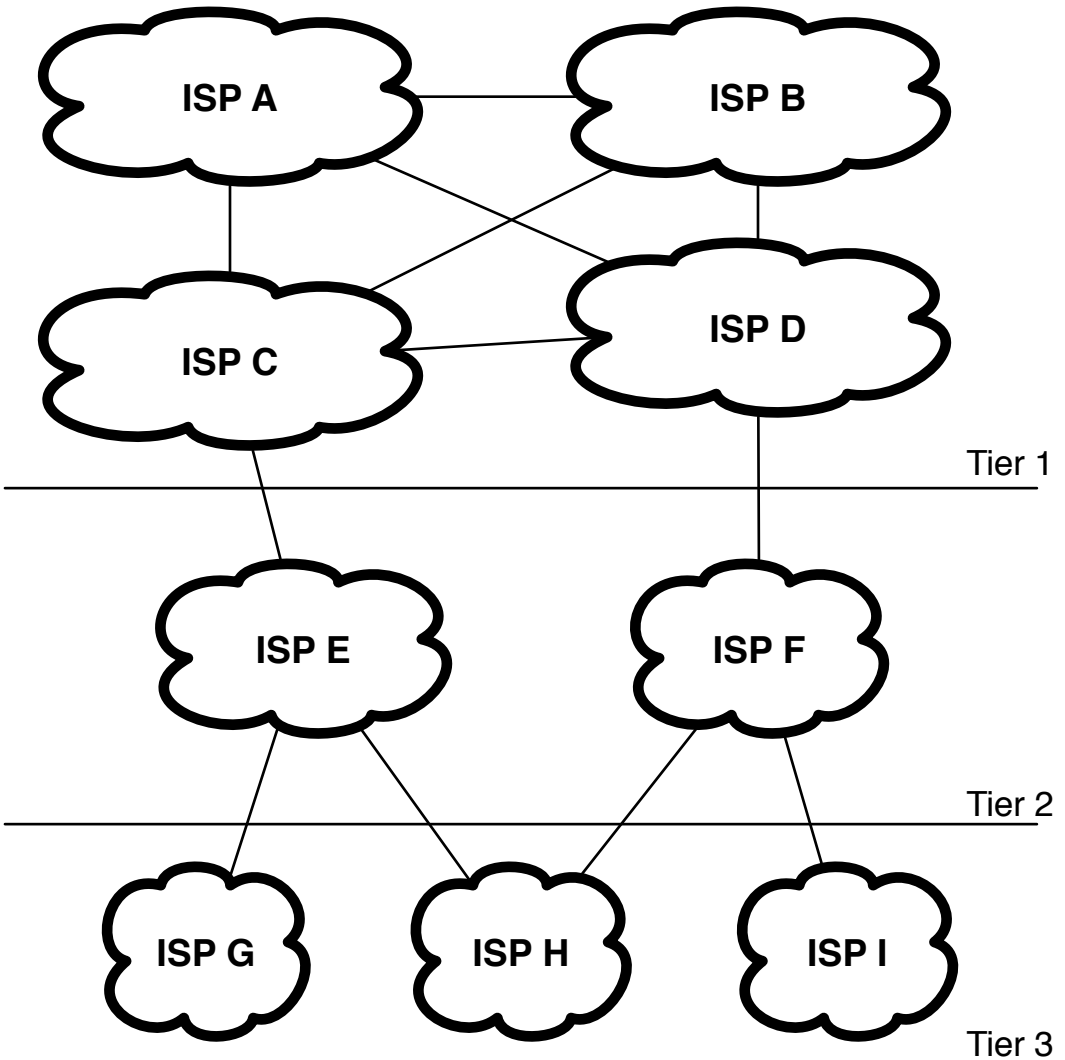

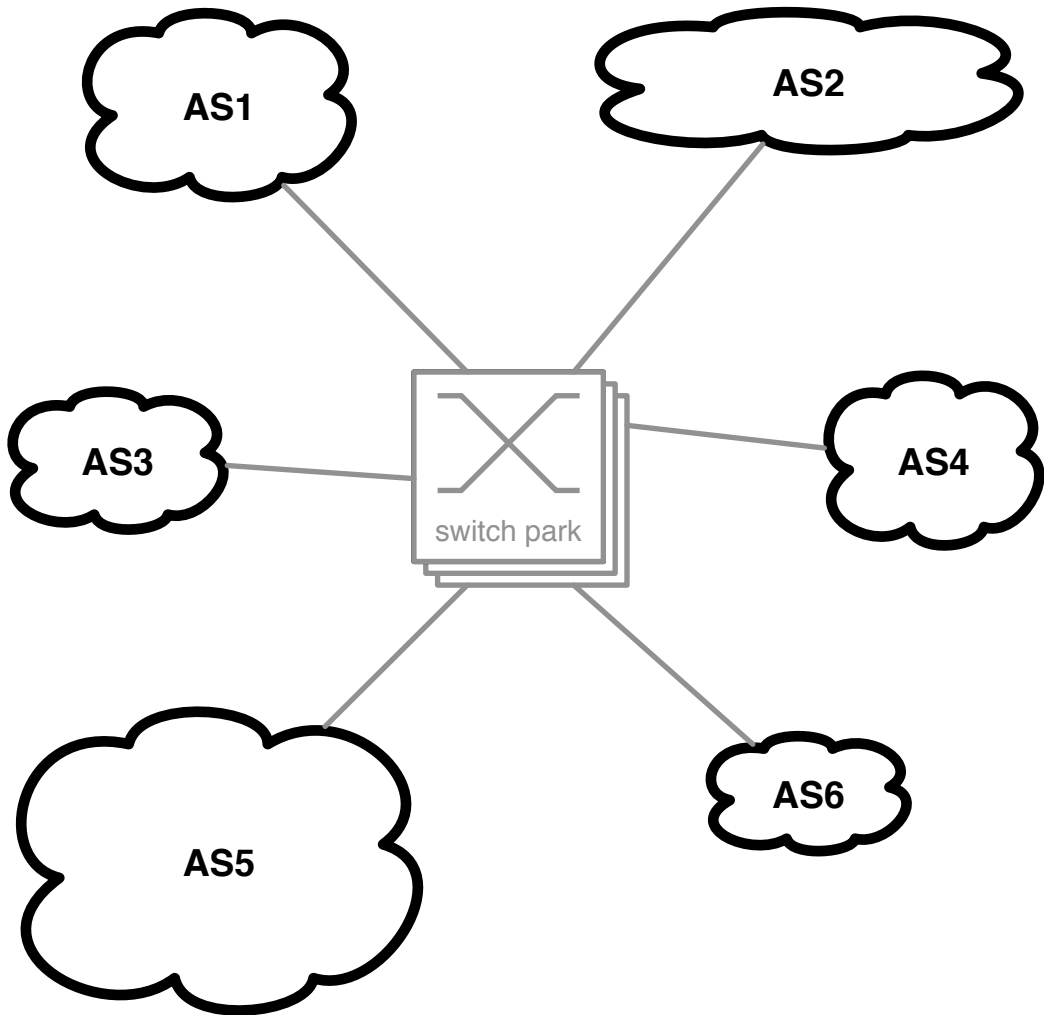

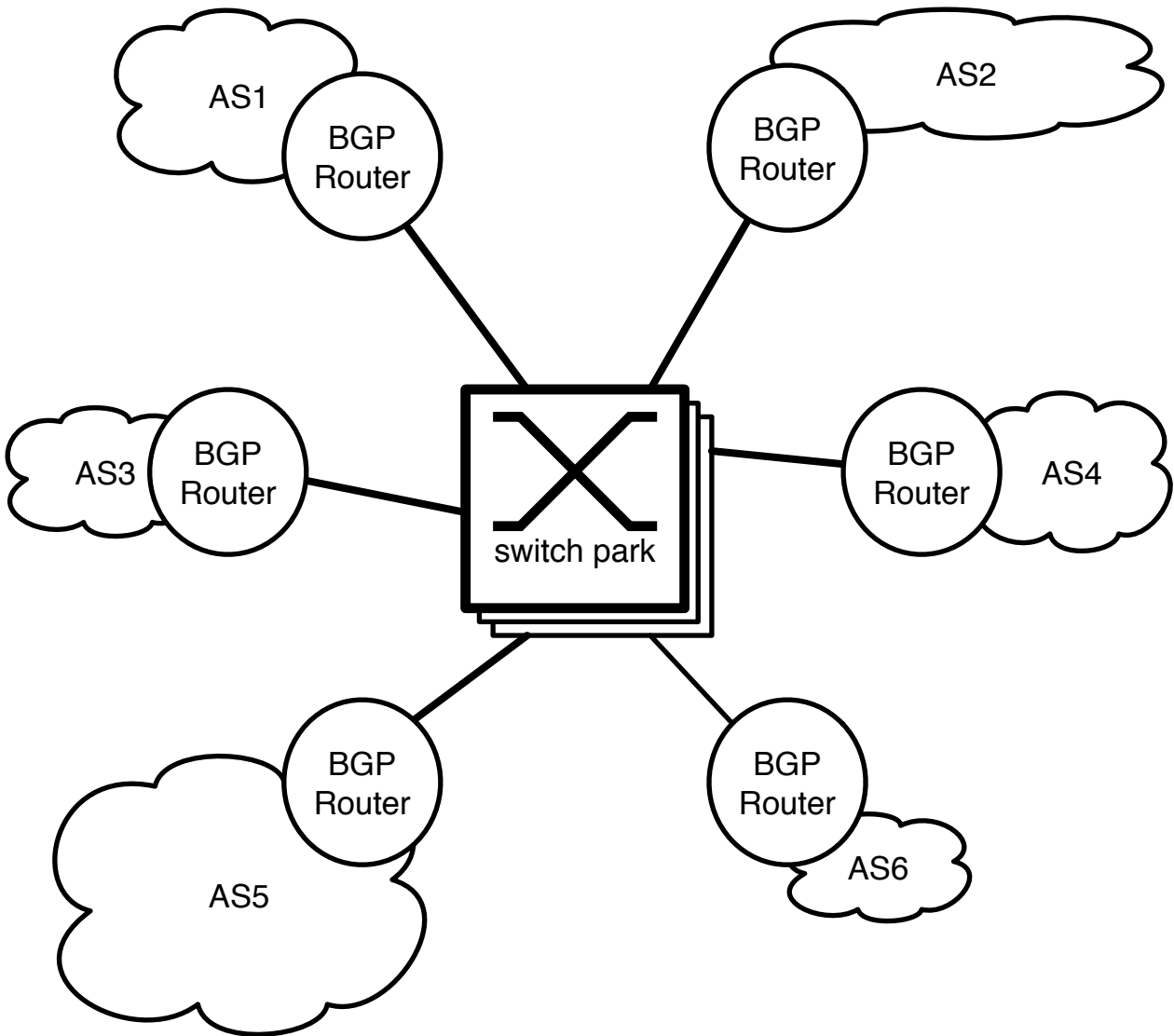

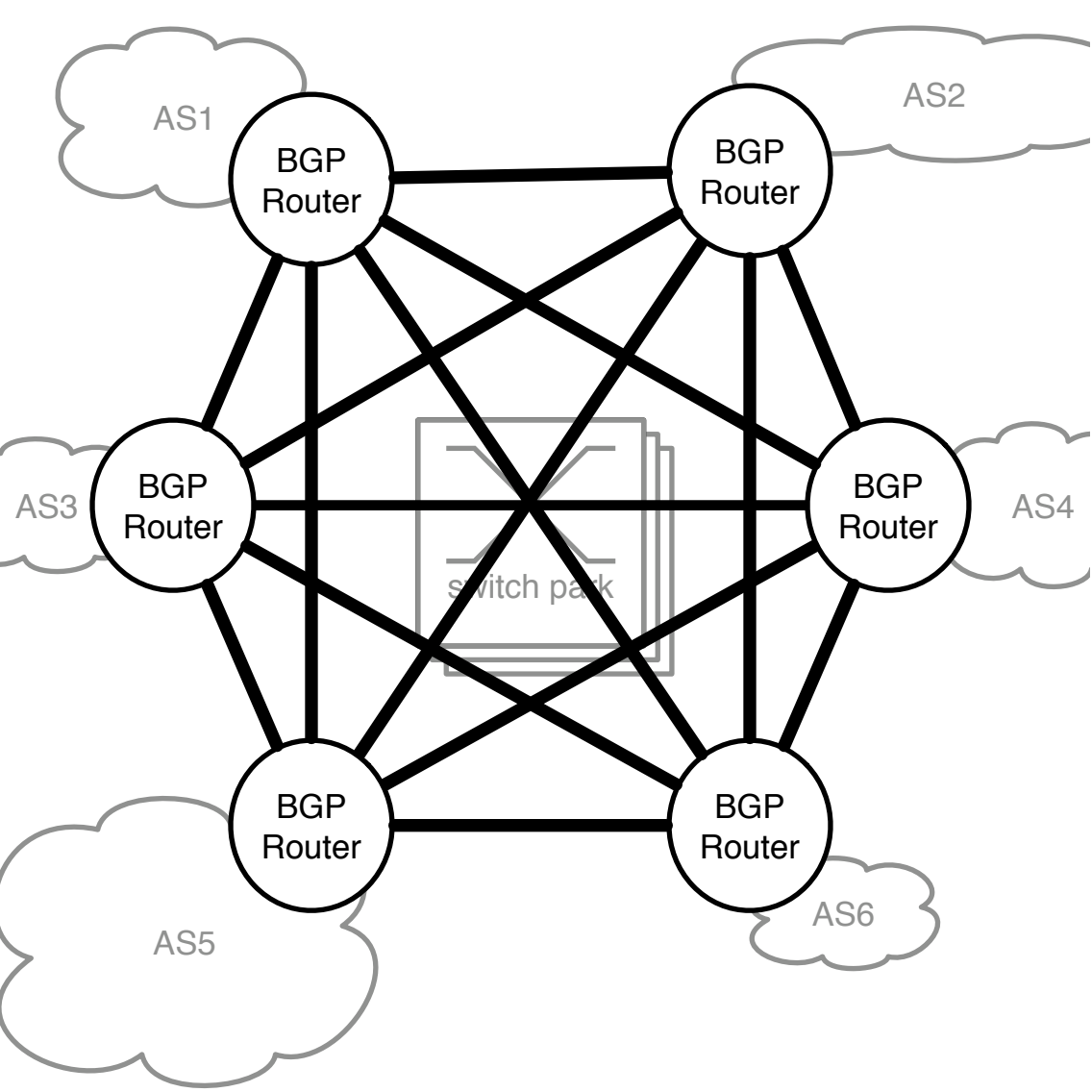

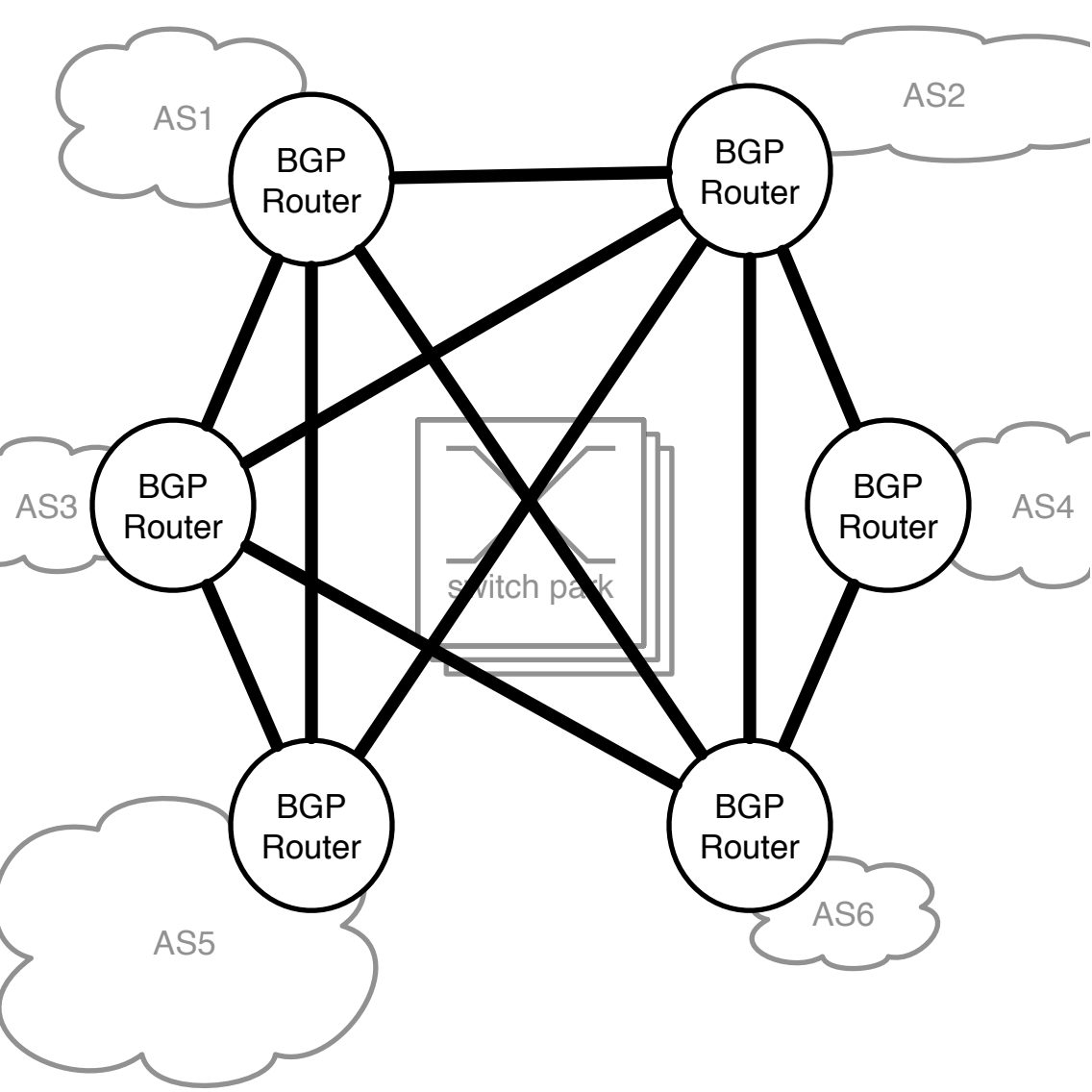

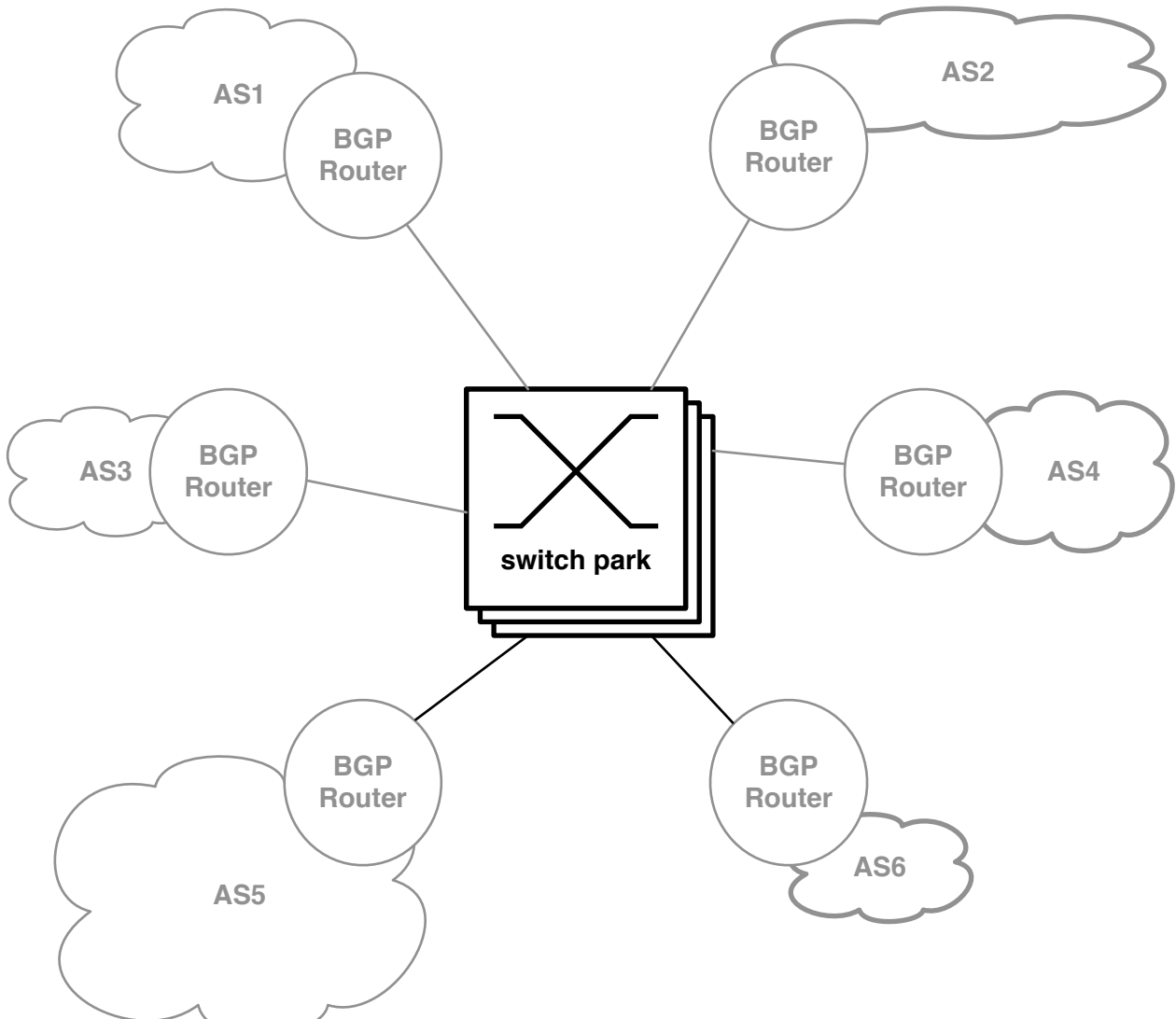

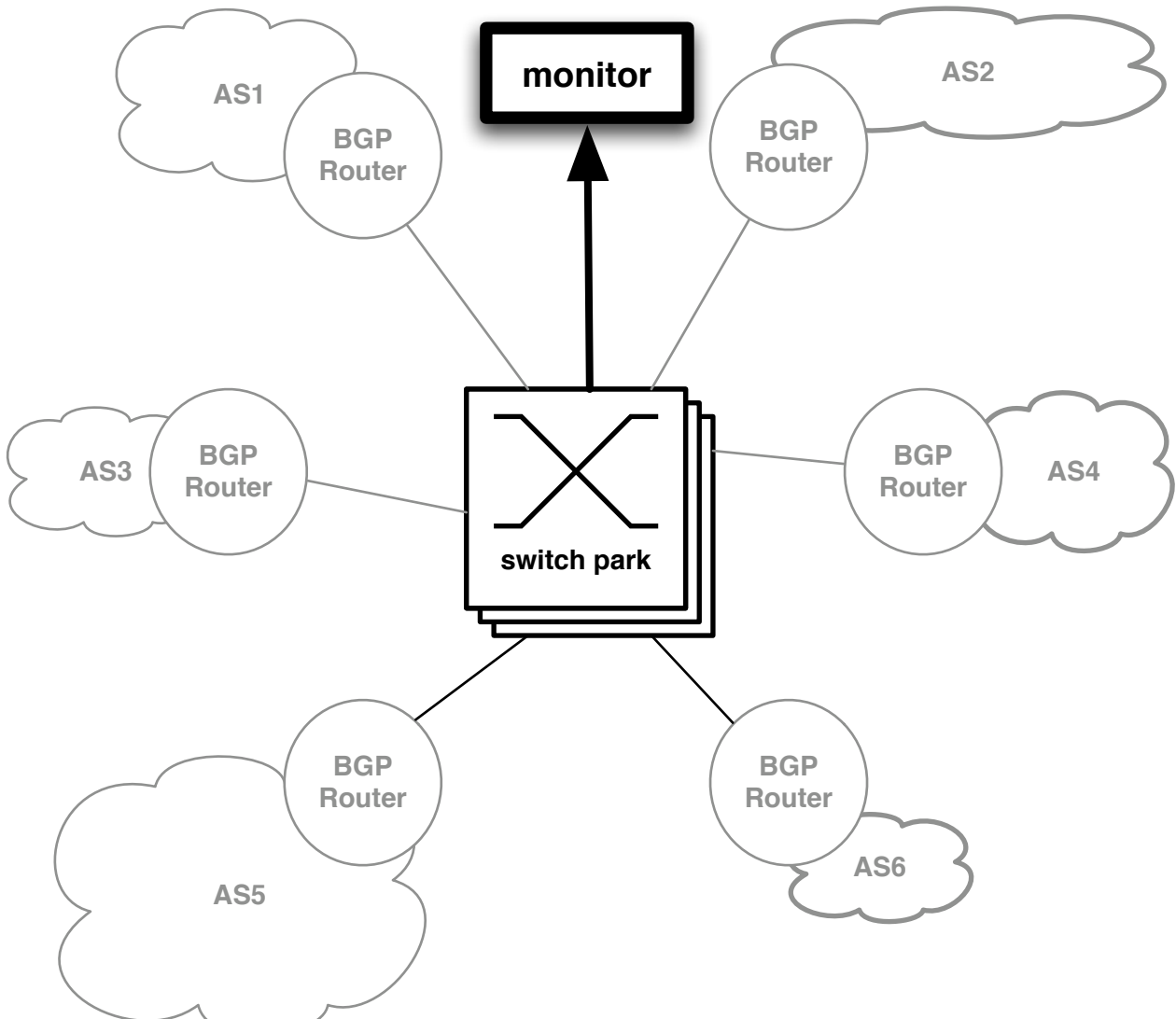

Example #1

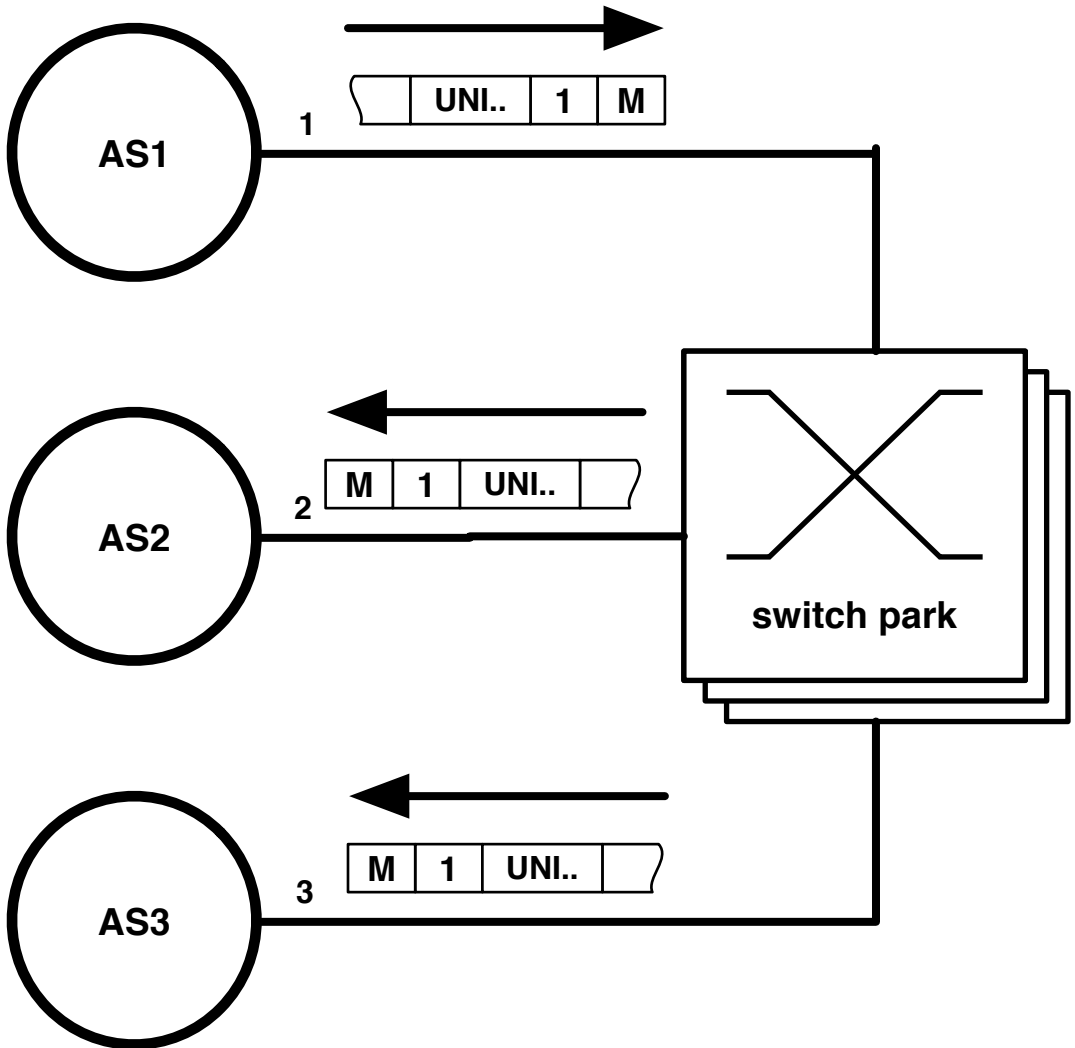

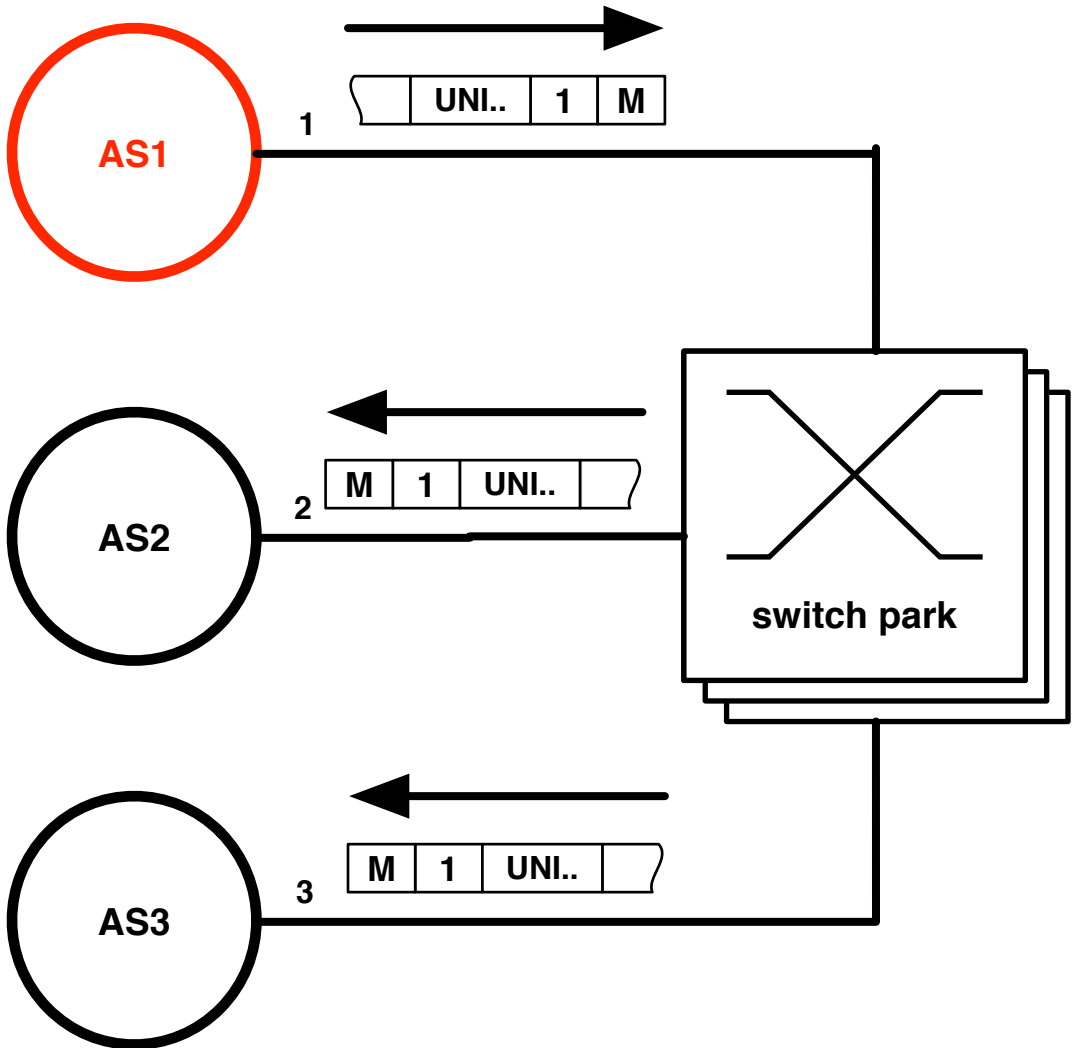

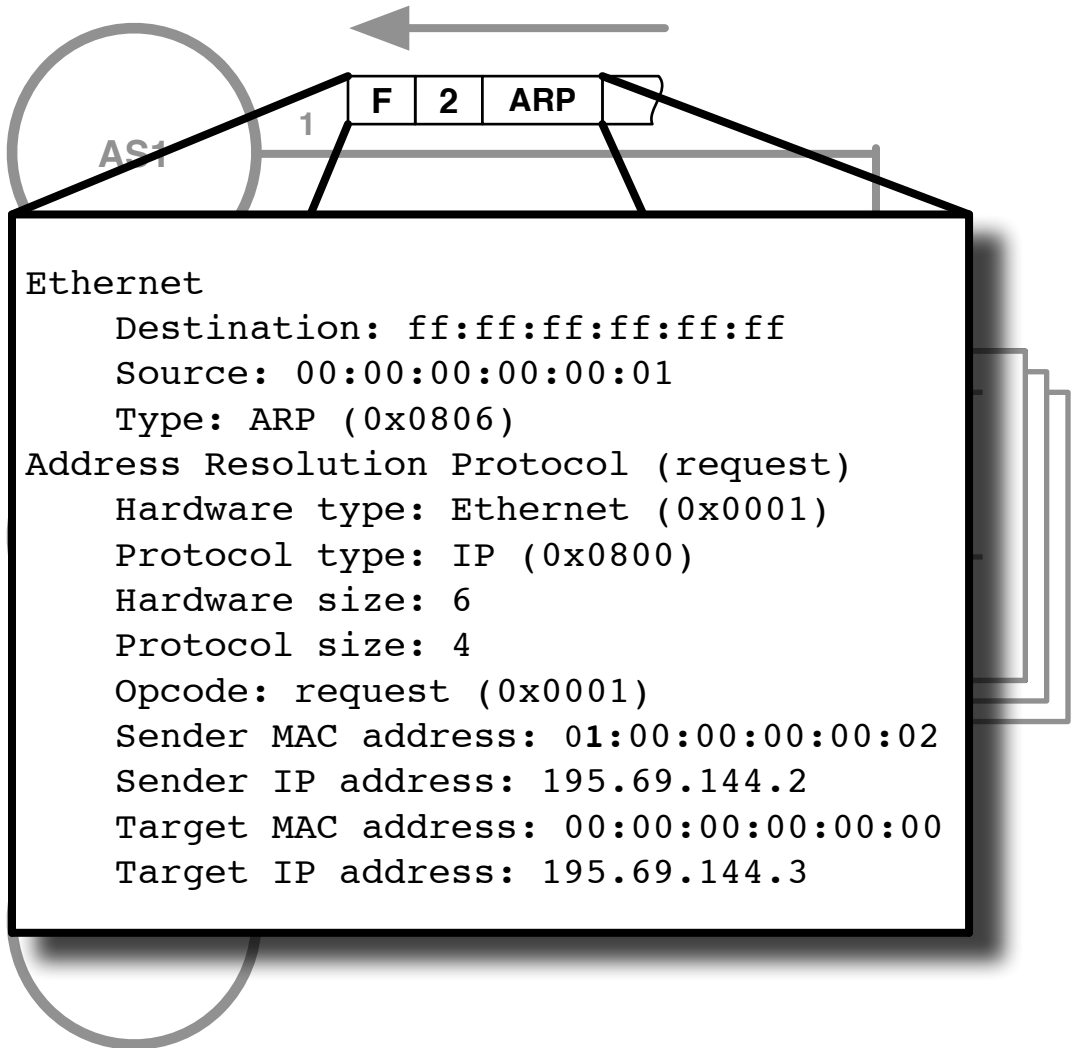

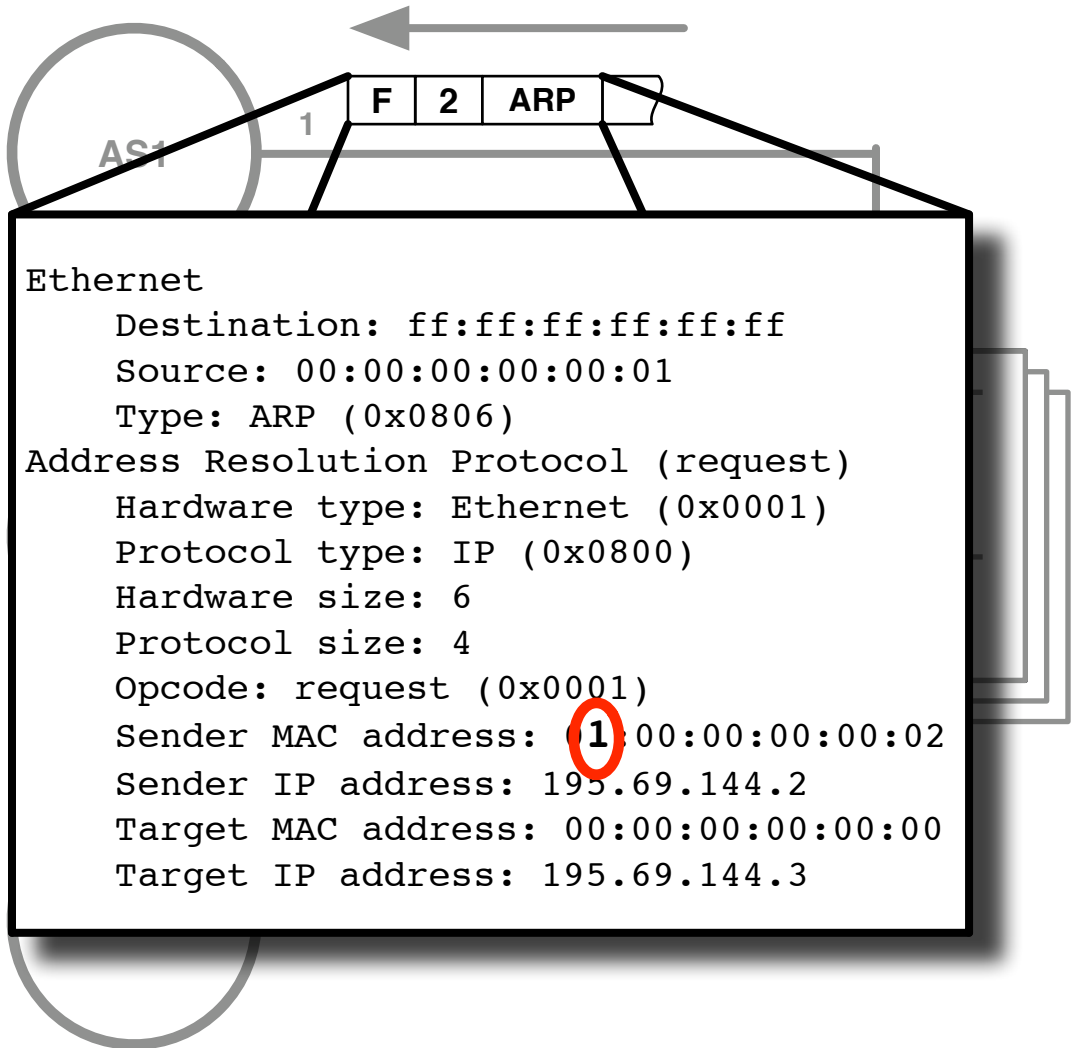

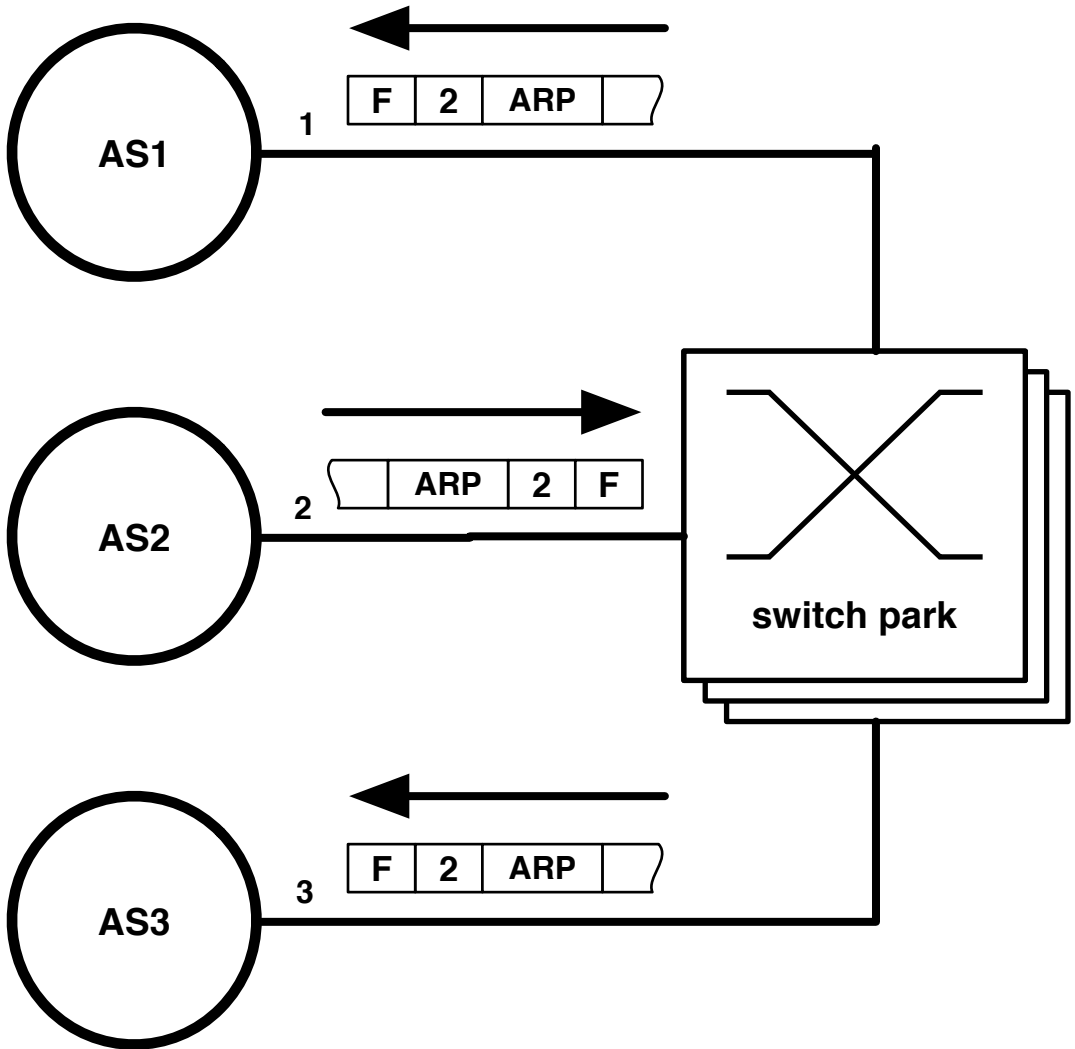

Tuttle

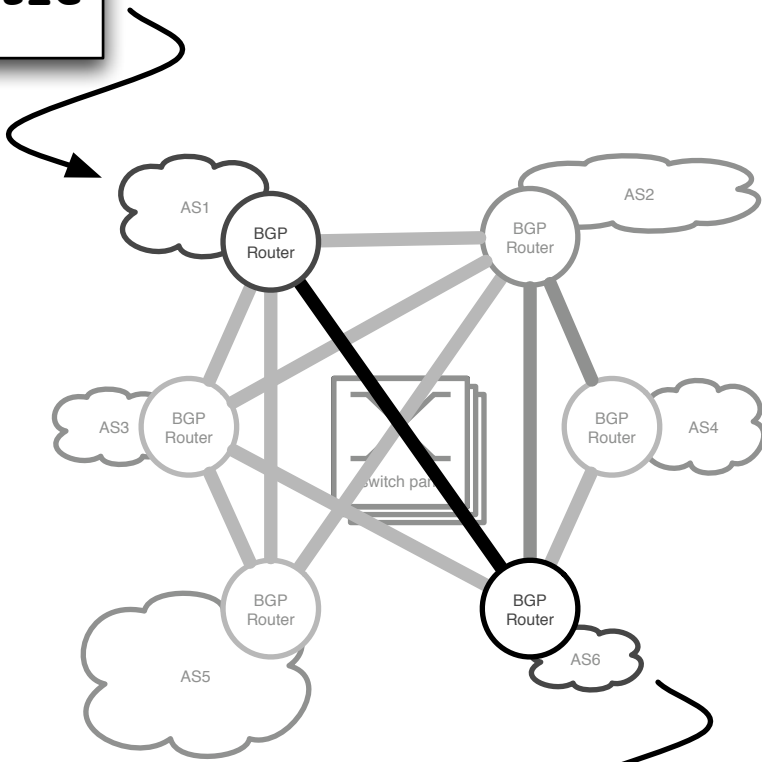

Buttle



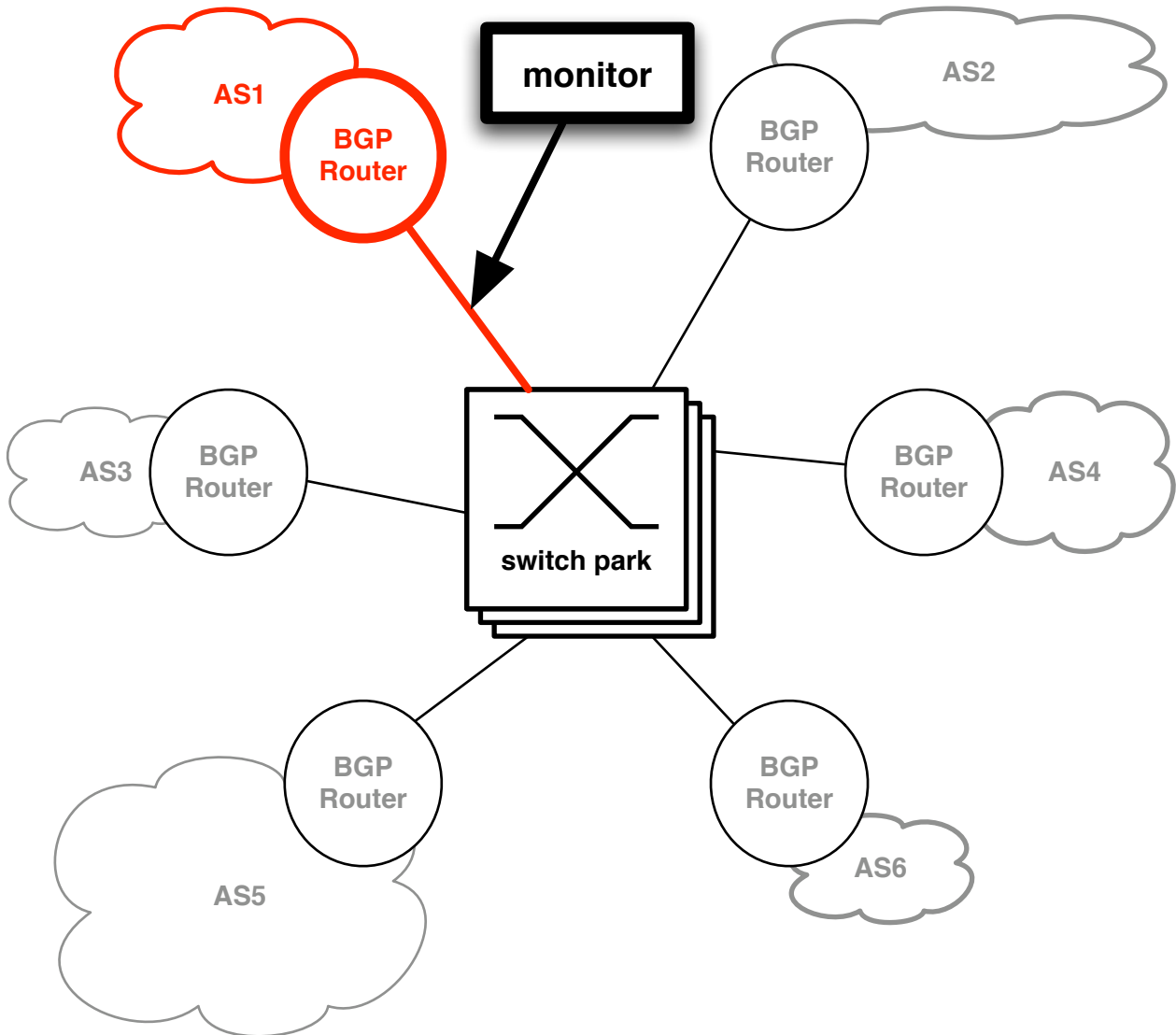

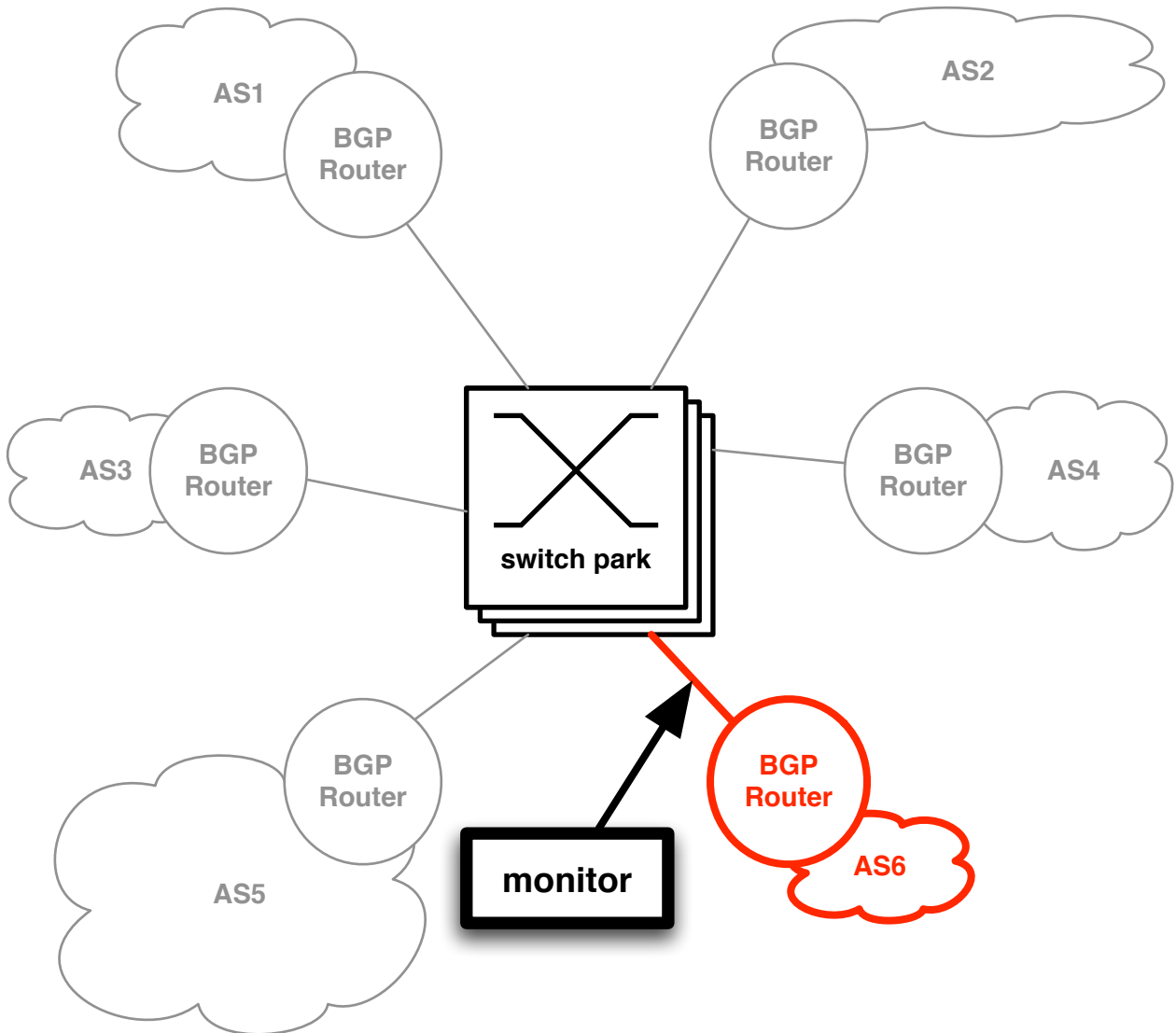

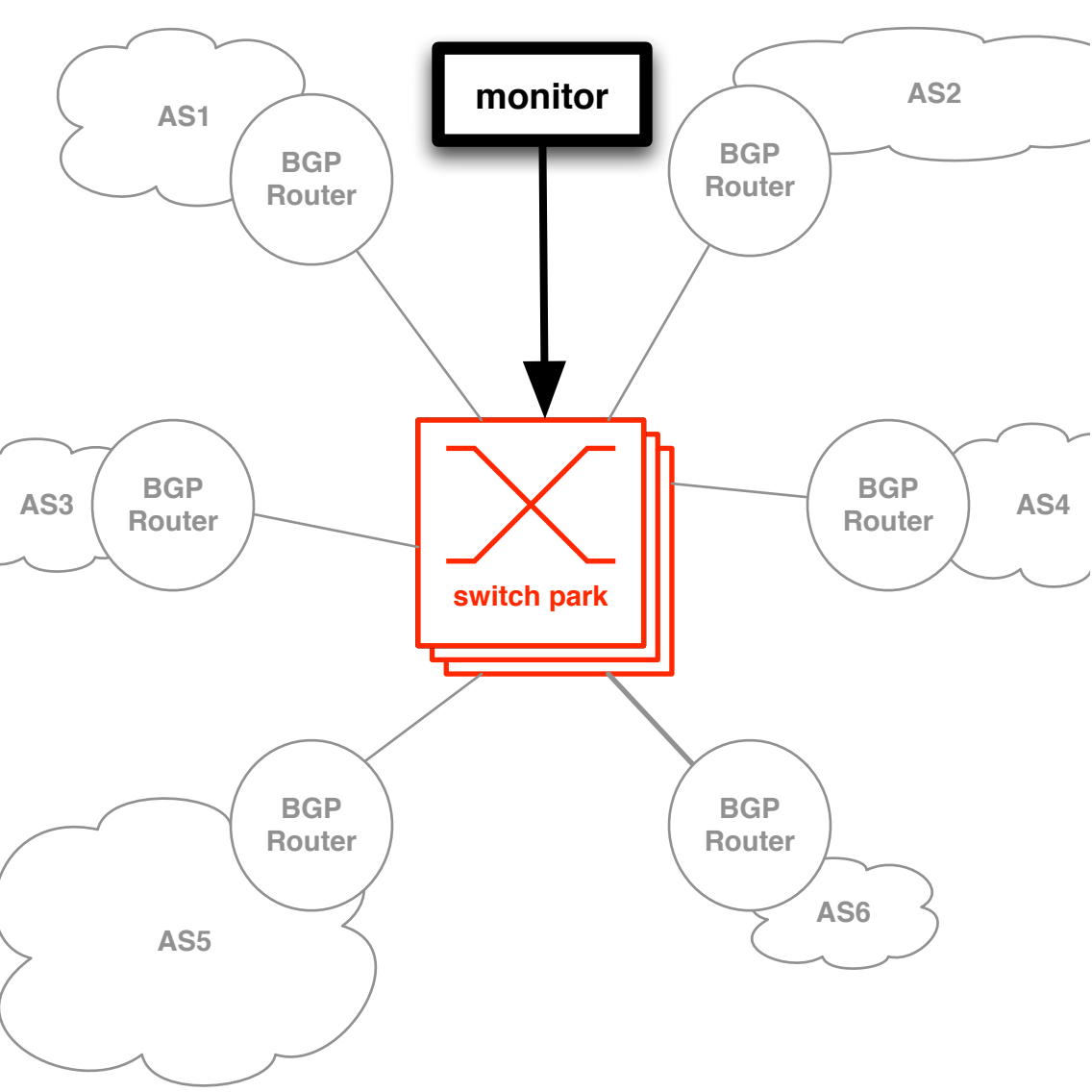

Example #2

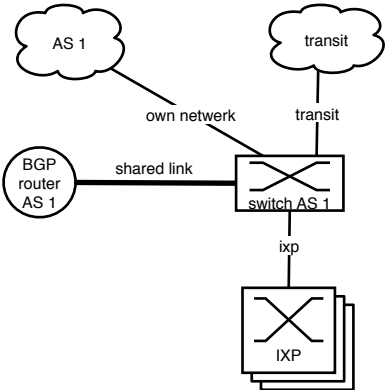

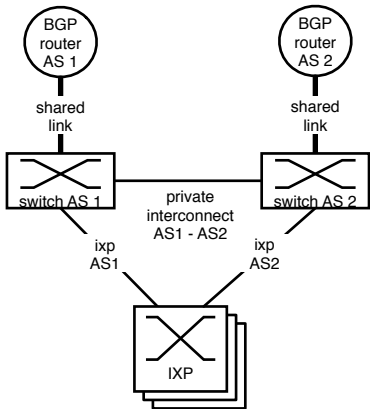

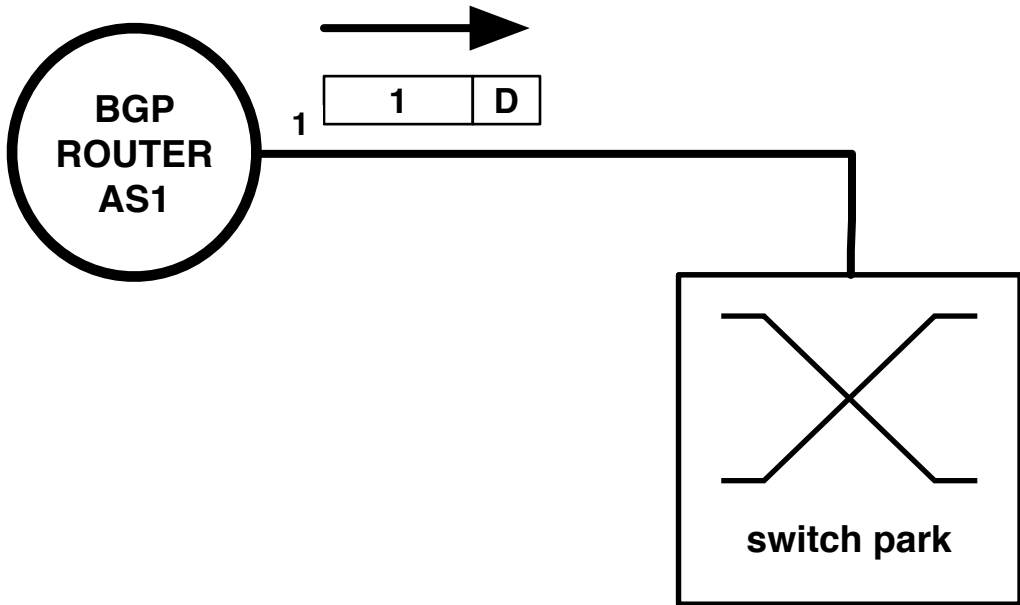

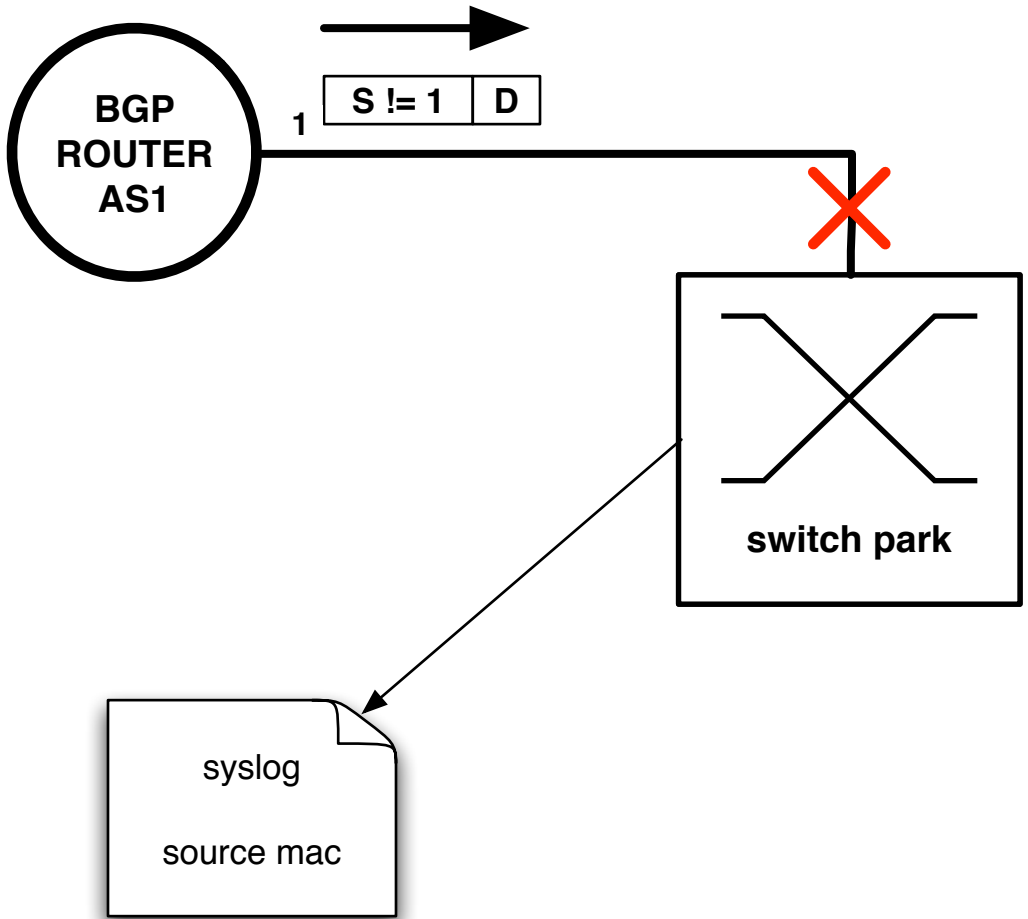

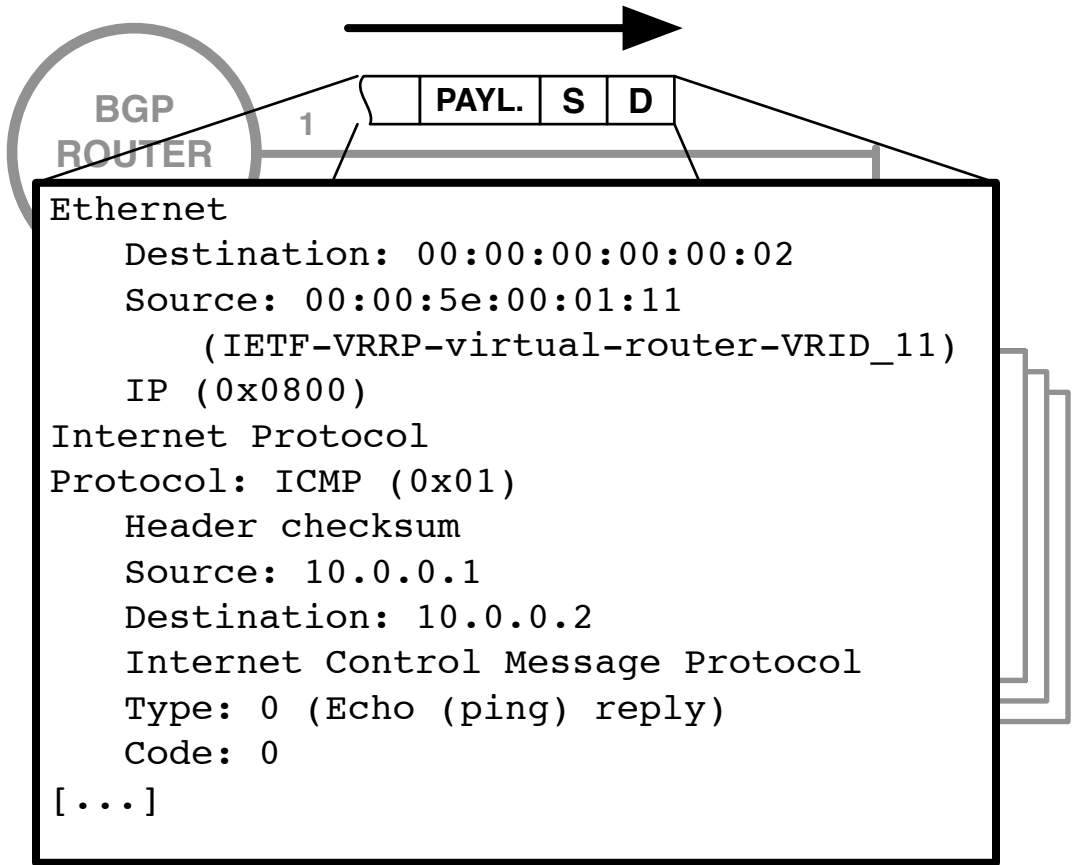

Monitoring

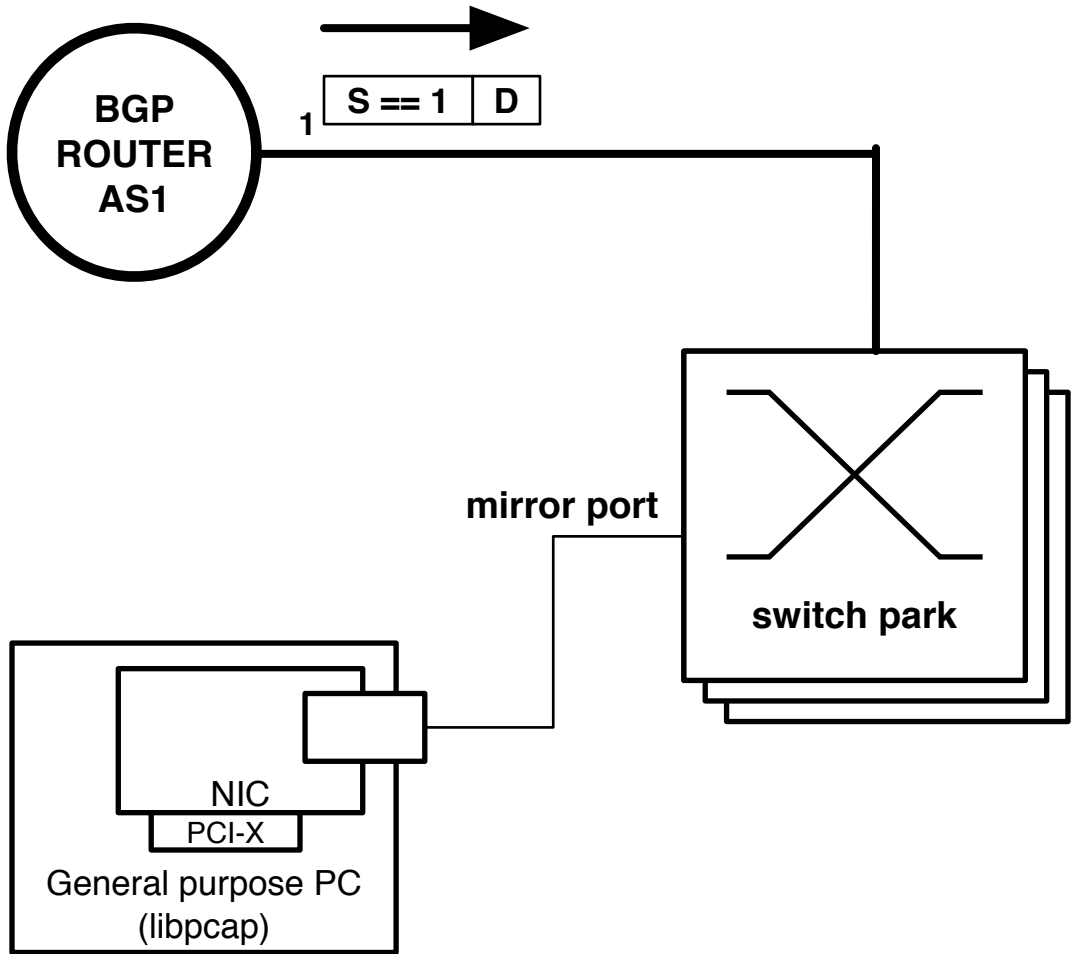

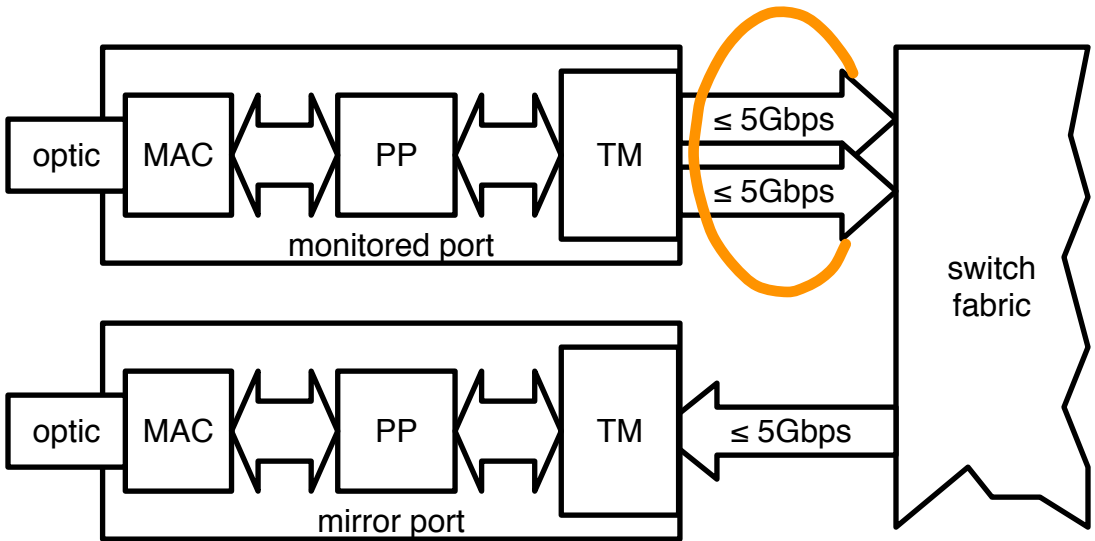

Router

**Ethernet
switch**

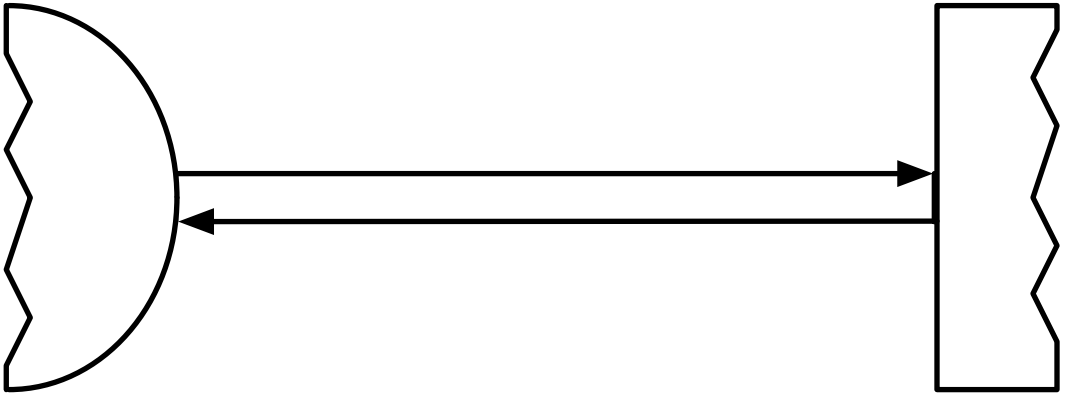

Router

**Ethernet
switch**

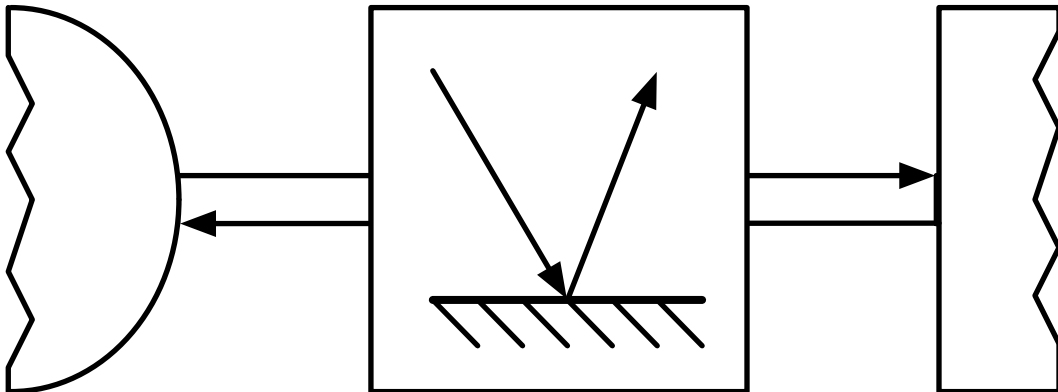

MEMS based Fiber Switch

AKA Photonic Cross Connect (PXC)

Fiber Lens Array

Fixed Mirror

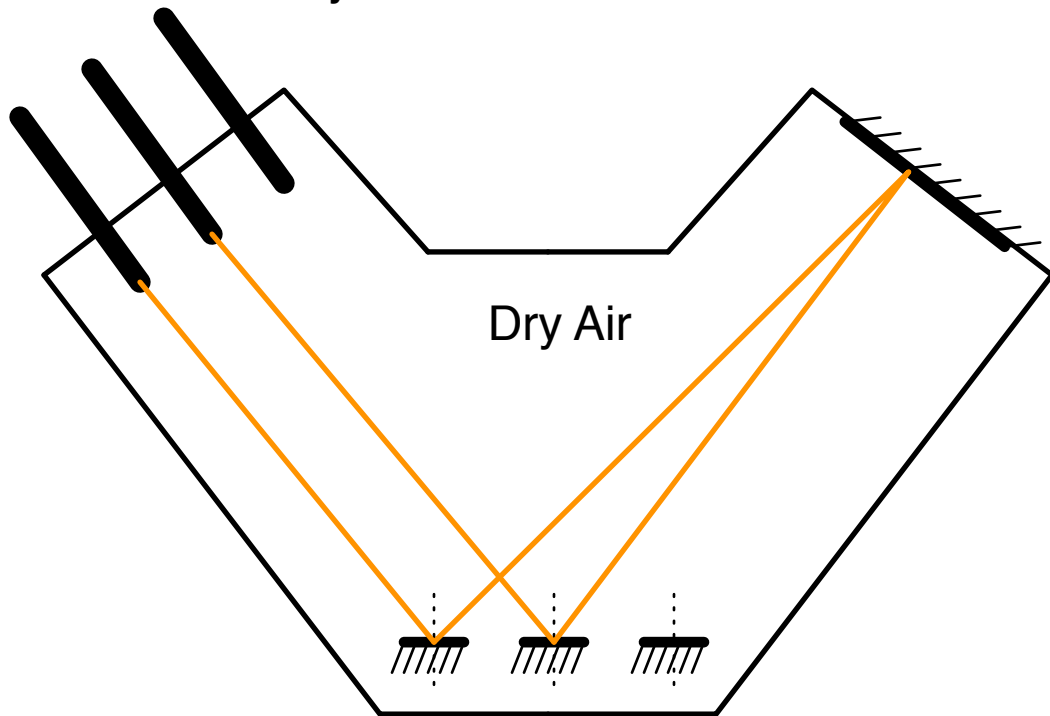

Dry Air

Movable Mirror Array

Fiber Lens Array

Fixed Mirror

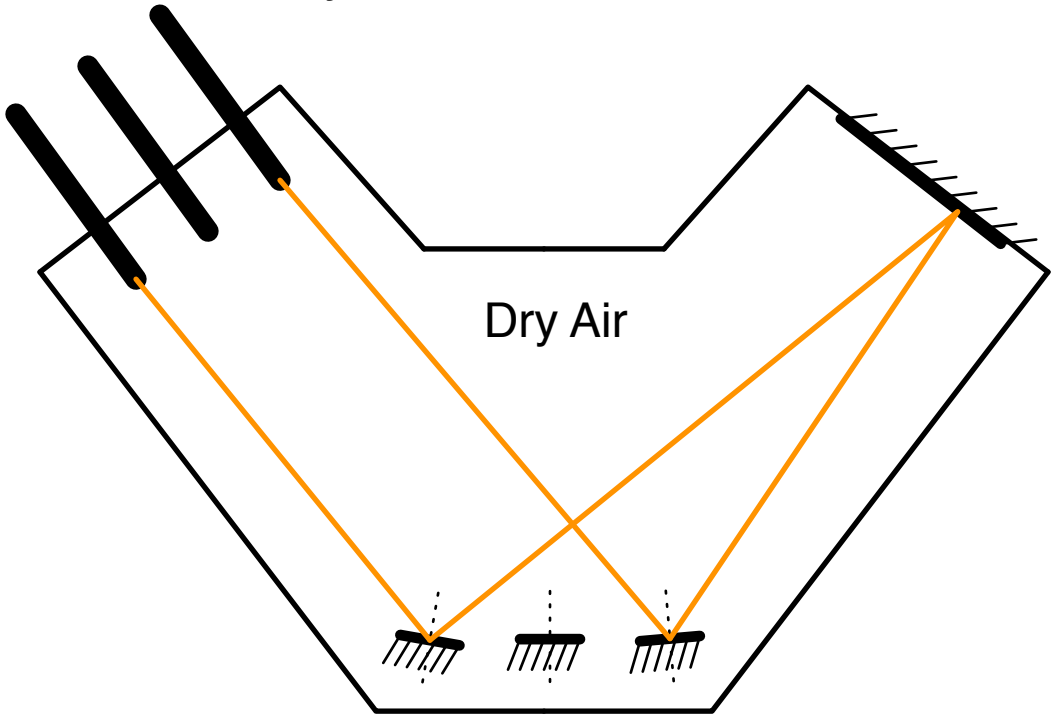

Dry Air

Movable Mirror Array

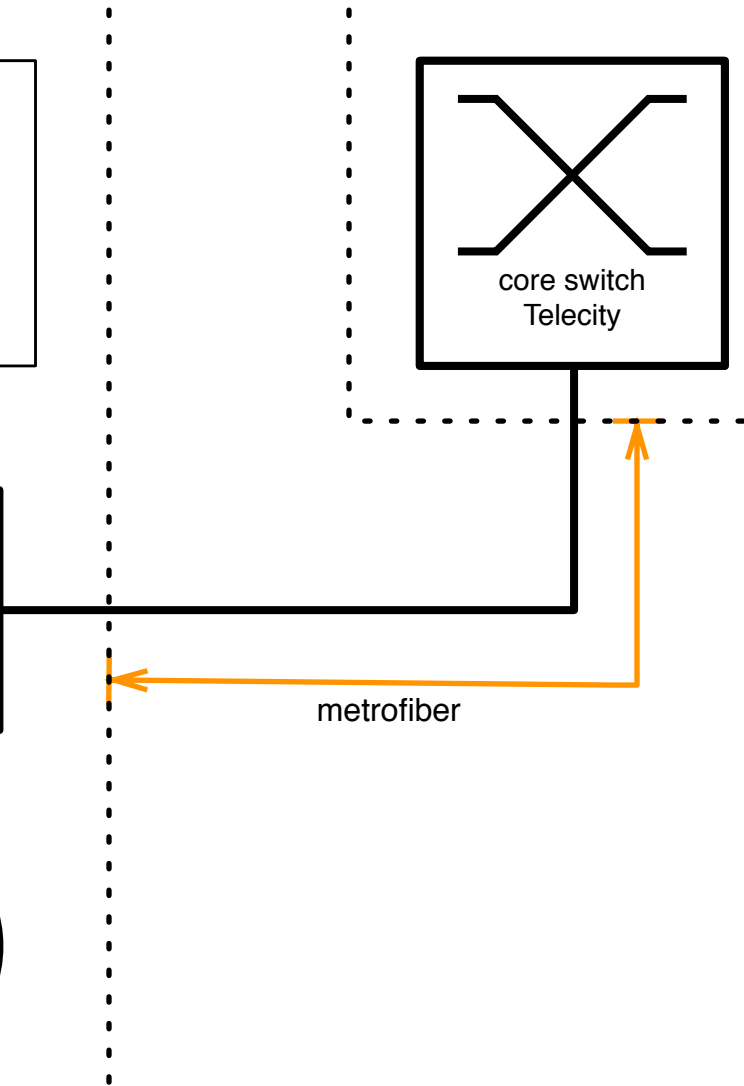
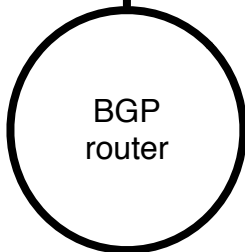
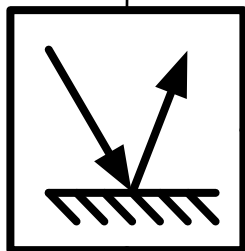
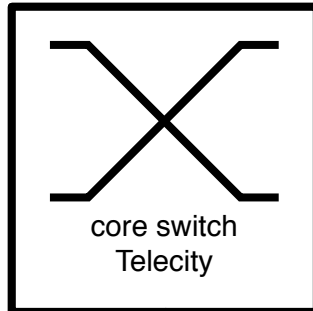
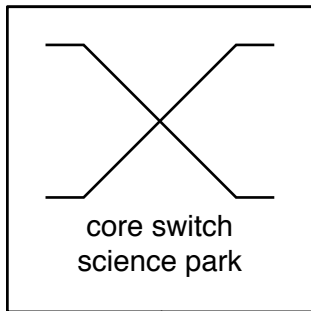

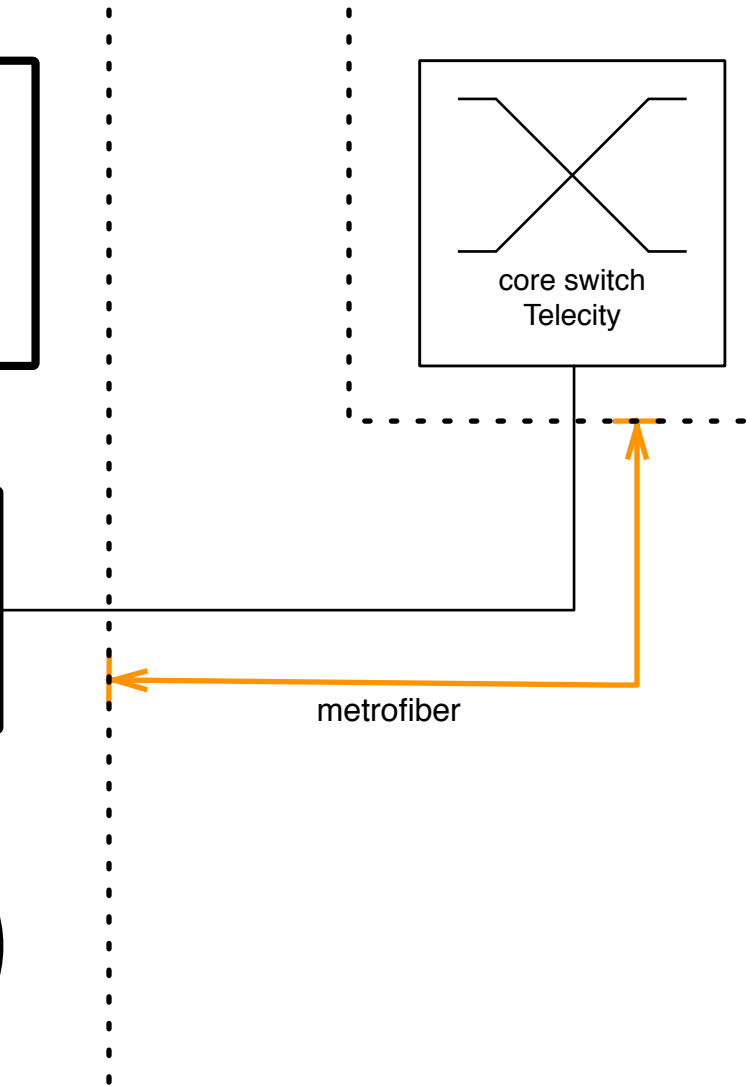
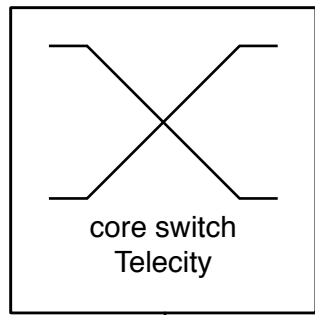
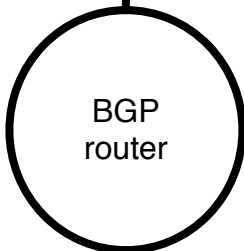
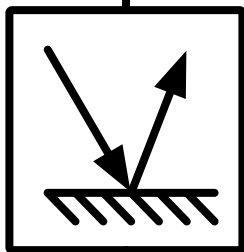
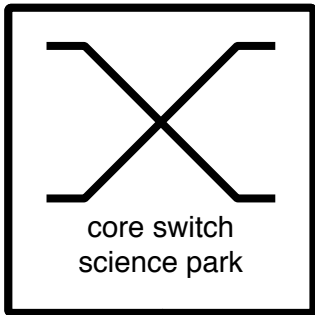

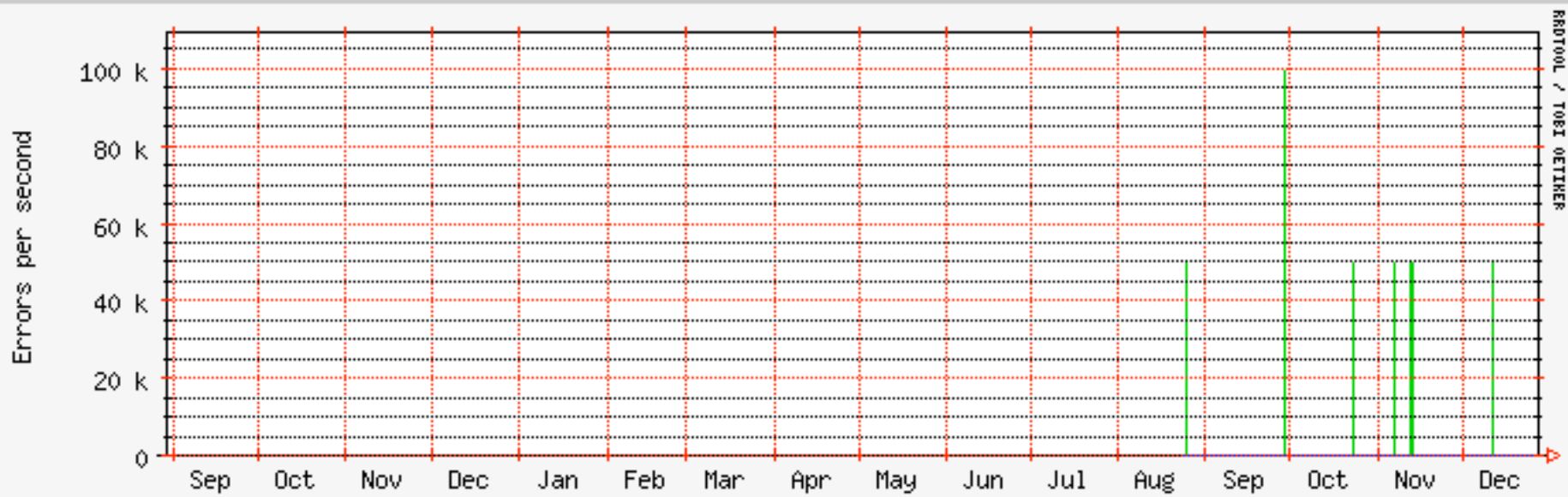

■ Input ■ Output

Max In : 99.420 kpkt/s Max Out : 0.000 pkt/s
 Average In : 2.741 kpkt/s Average Out : 0.000 pkt/s
 Current In : 0.000 pkt/s Current Out : 0.000 pkt/s

Copyright (c) 2006 AMS-IX B.V. [updated: Fri Dec 29 10:47:40 2006]

Router

**AMS-IX
switch**

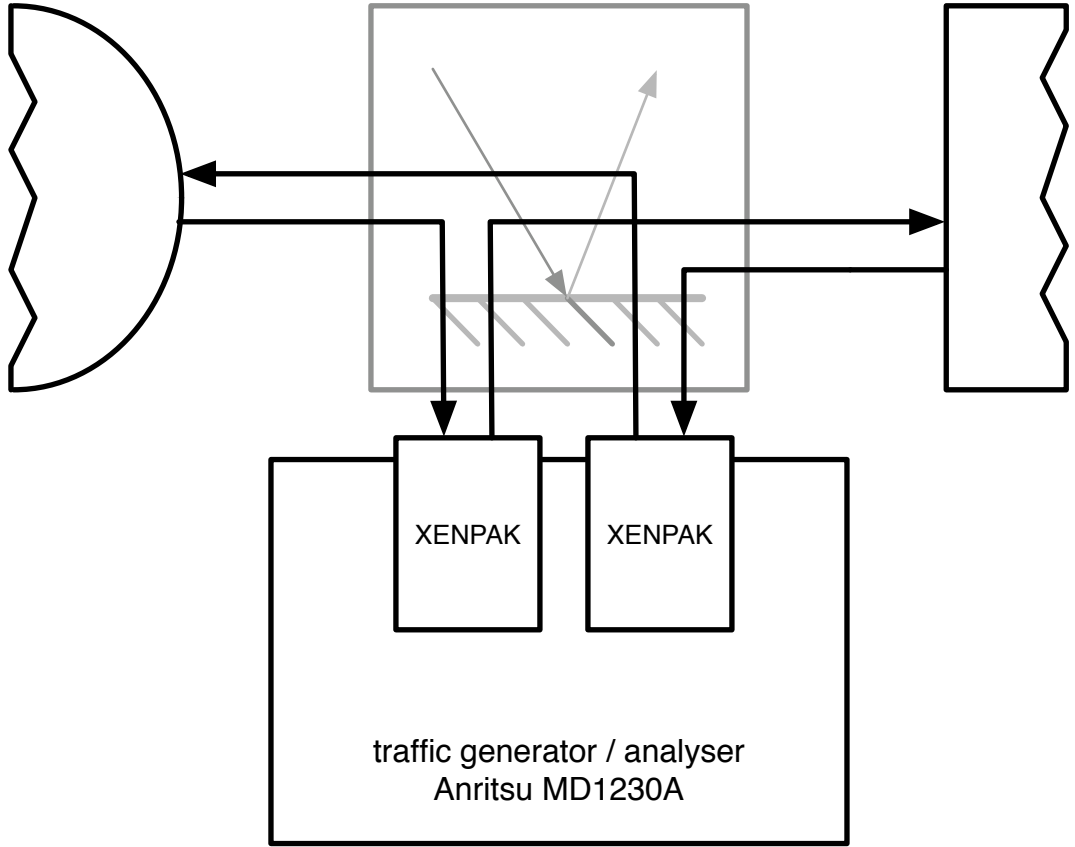

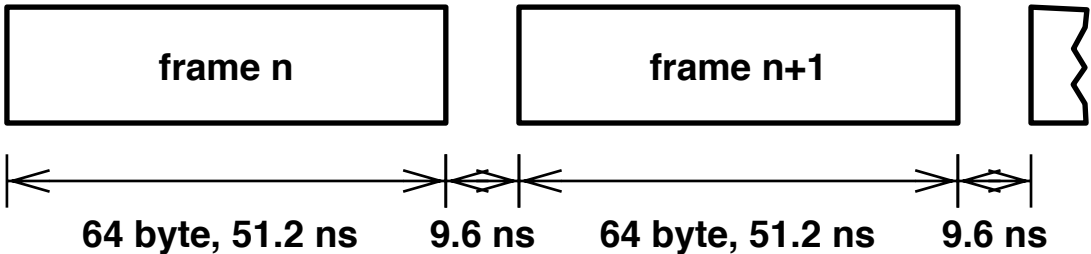

Solution

Router

**AMS-IX
switch**

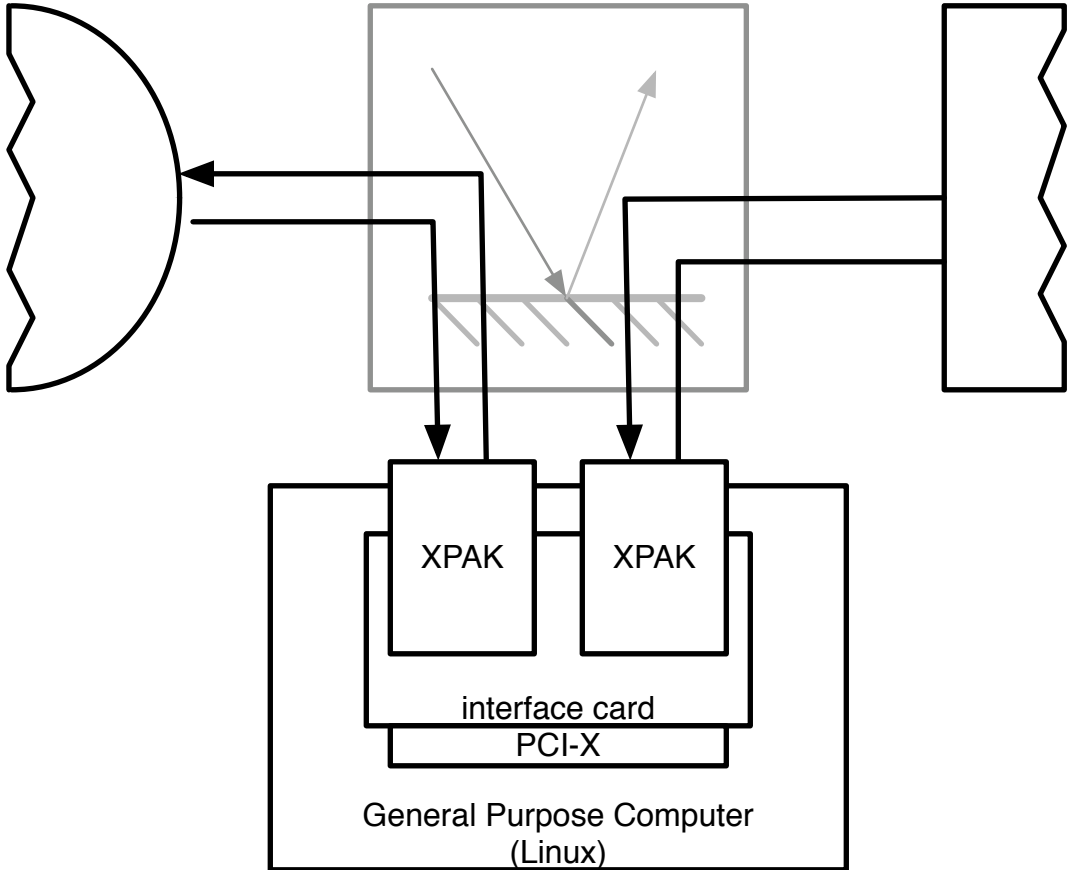

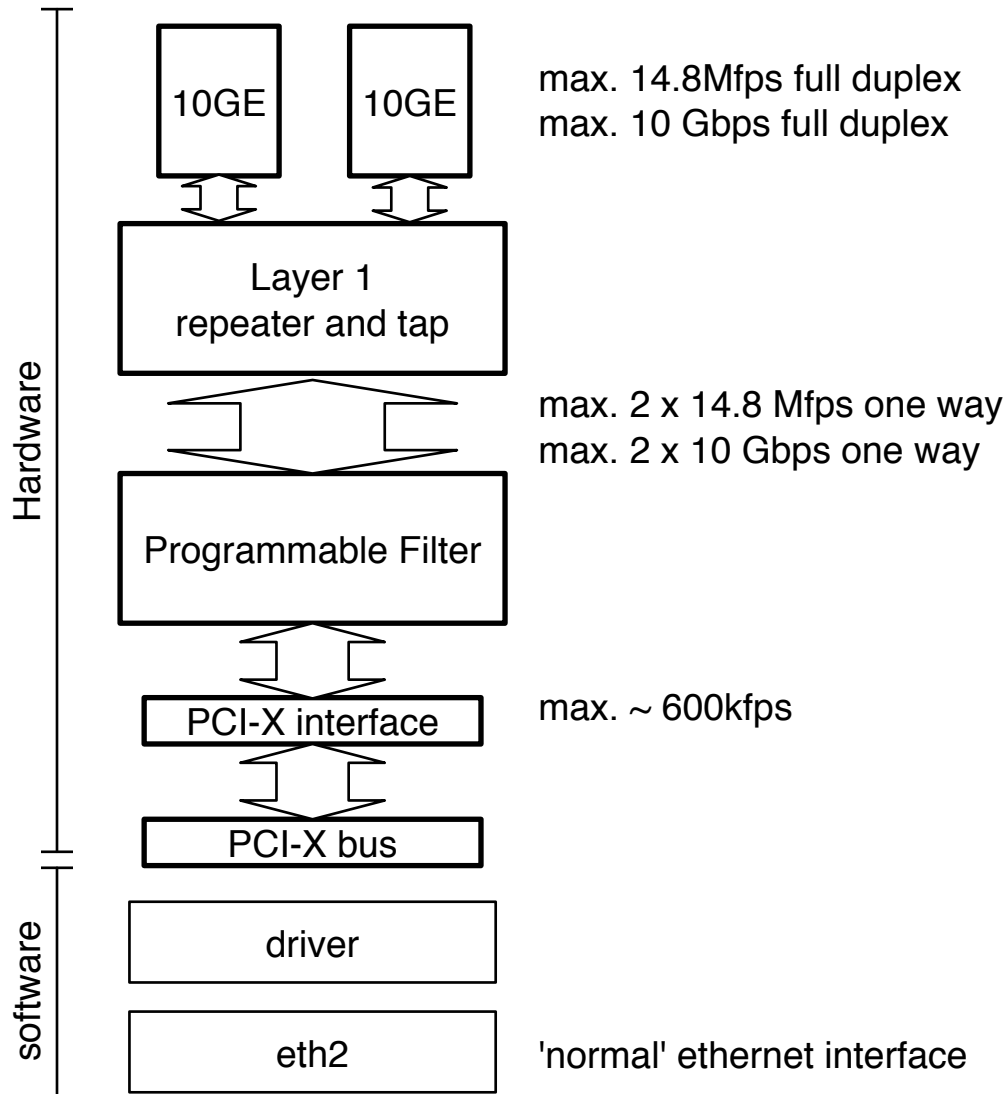

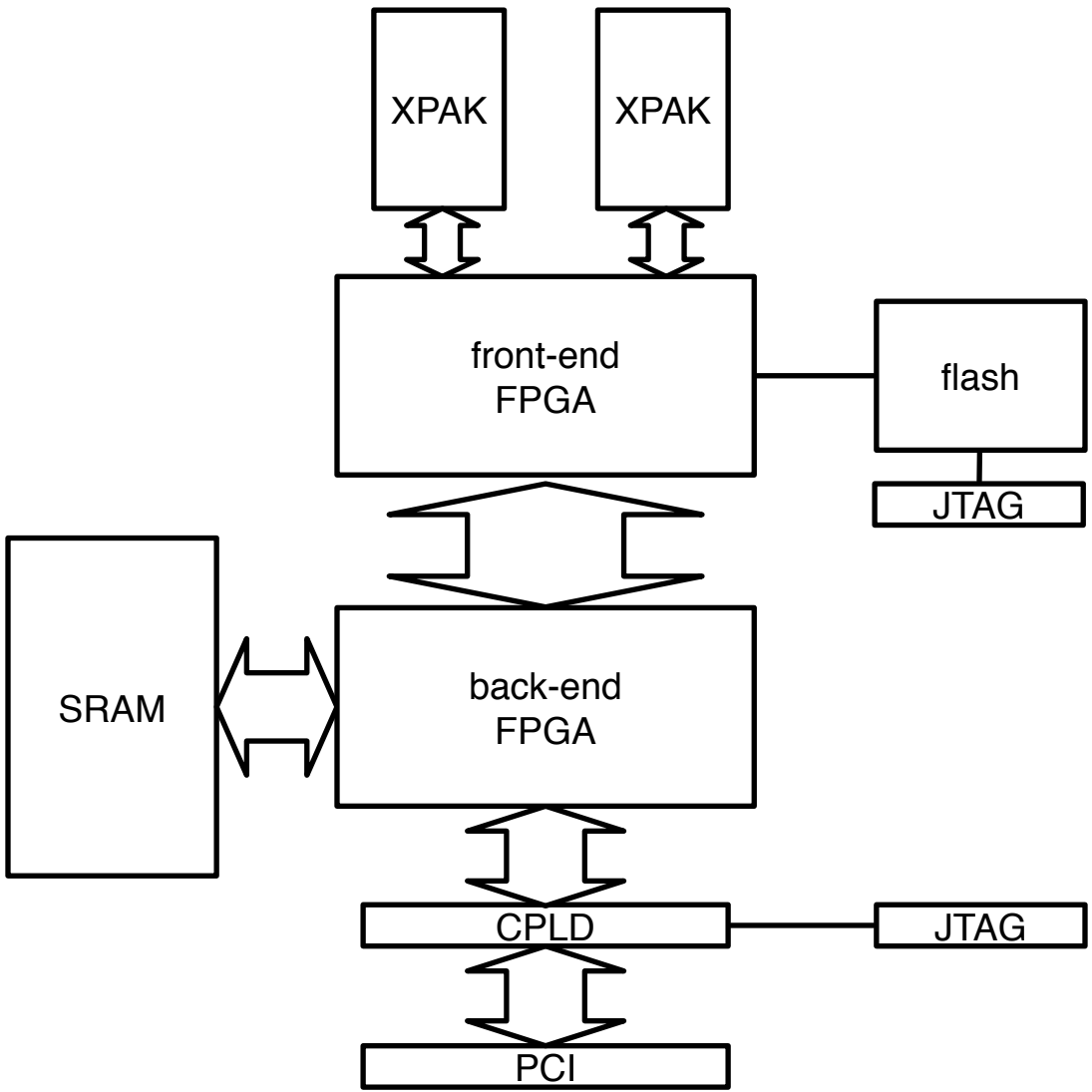

XPAK Transceivers

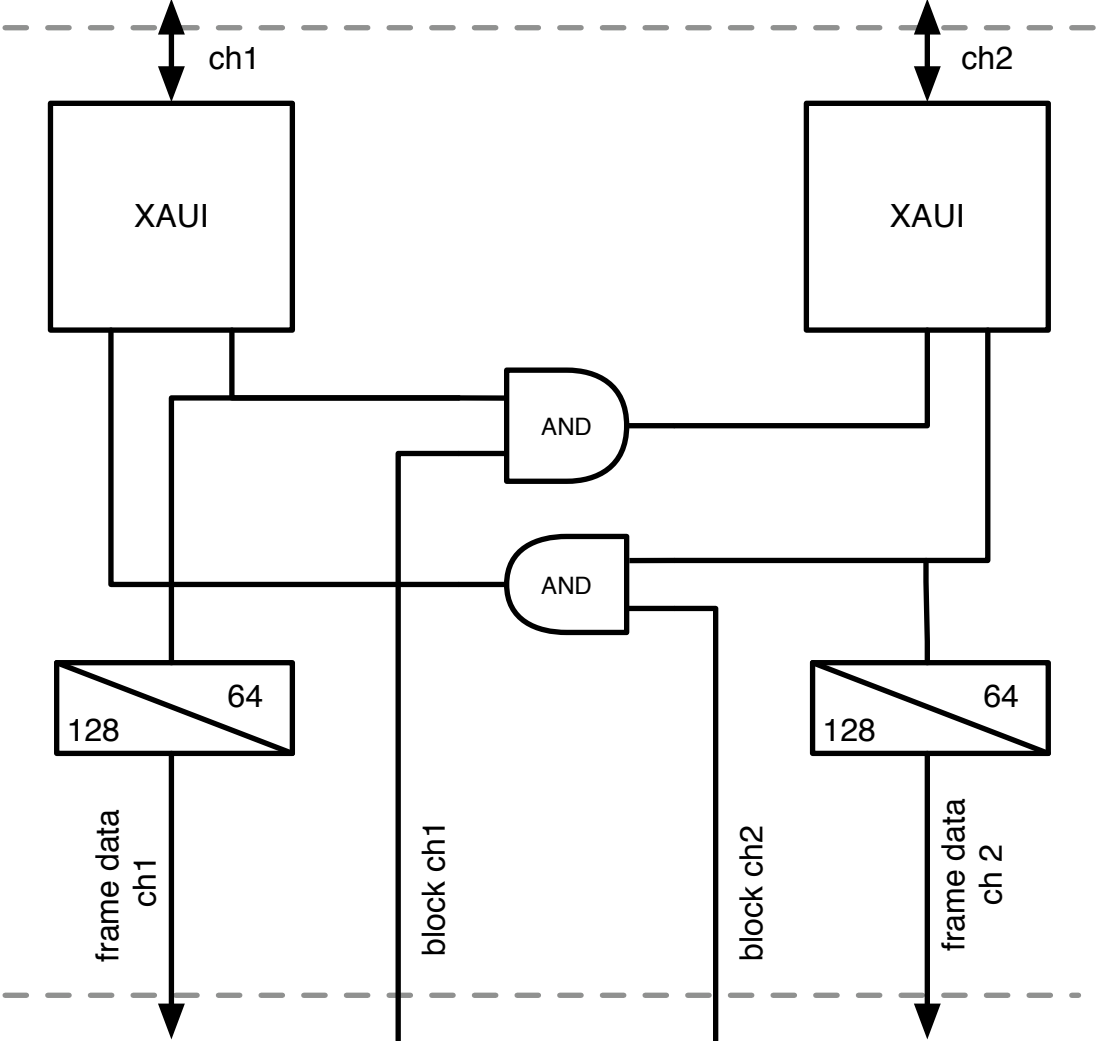

ch1

ch2

XAUI

XAUI

AND

AND

64

128

frame data
ch1

block ch1

block ch2

frame data
ch 2

back-end FPGA

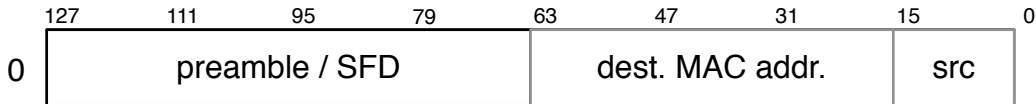

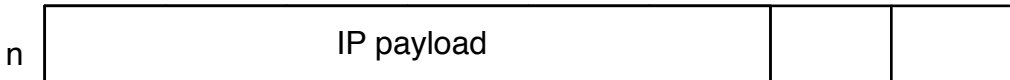
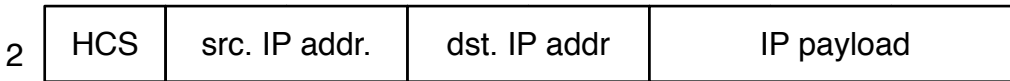
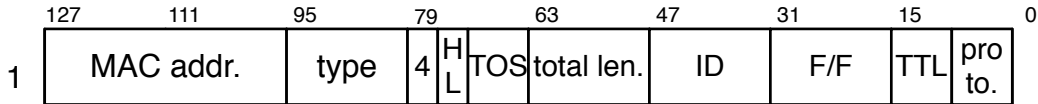

front-end FPGA

frame data

offset

valid

clk

frame data register

R_0

R_1

R_n

C_0

C_1

C_n

reduction network

match
memory

filtered
data

CPLD

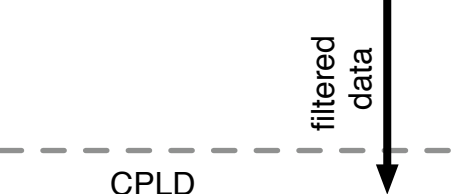
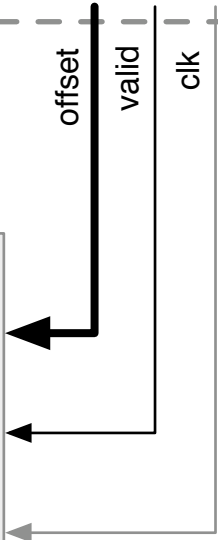
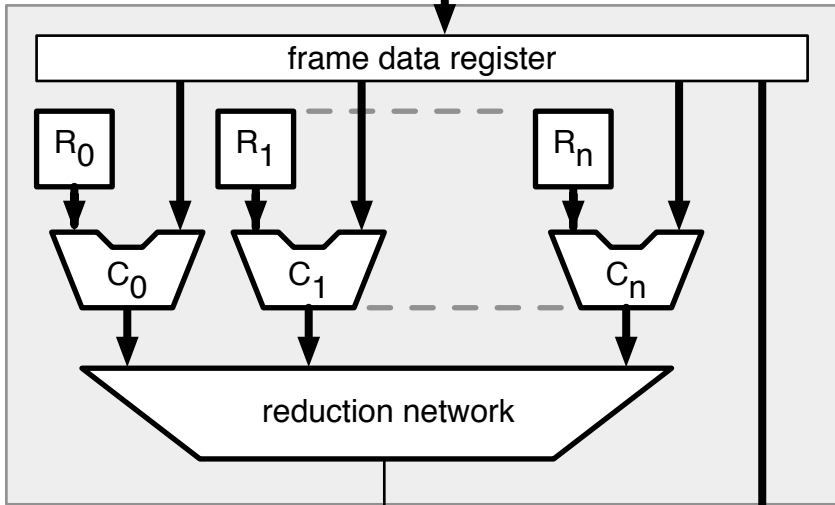

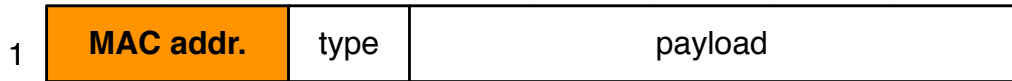
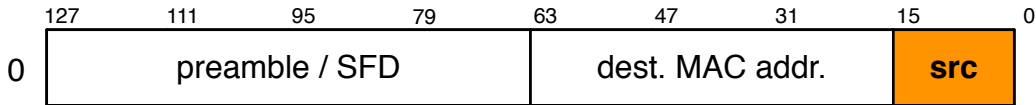

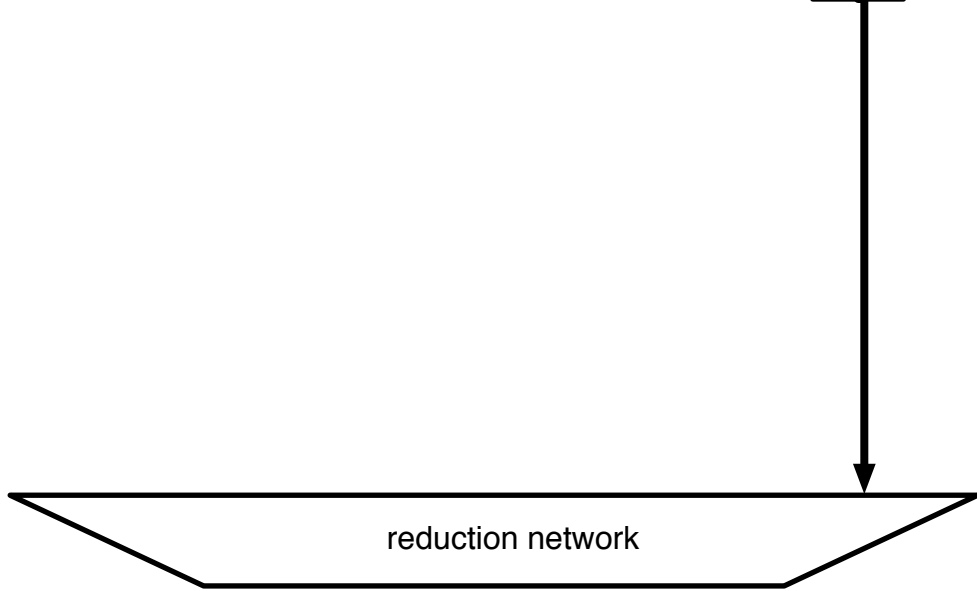
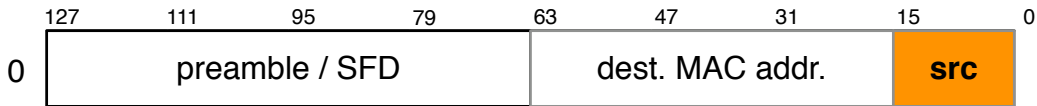

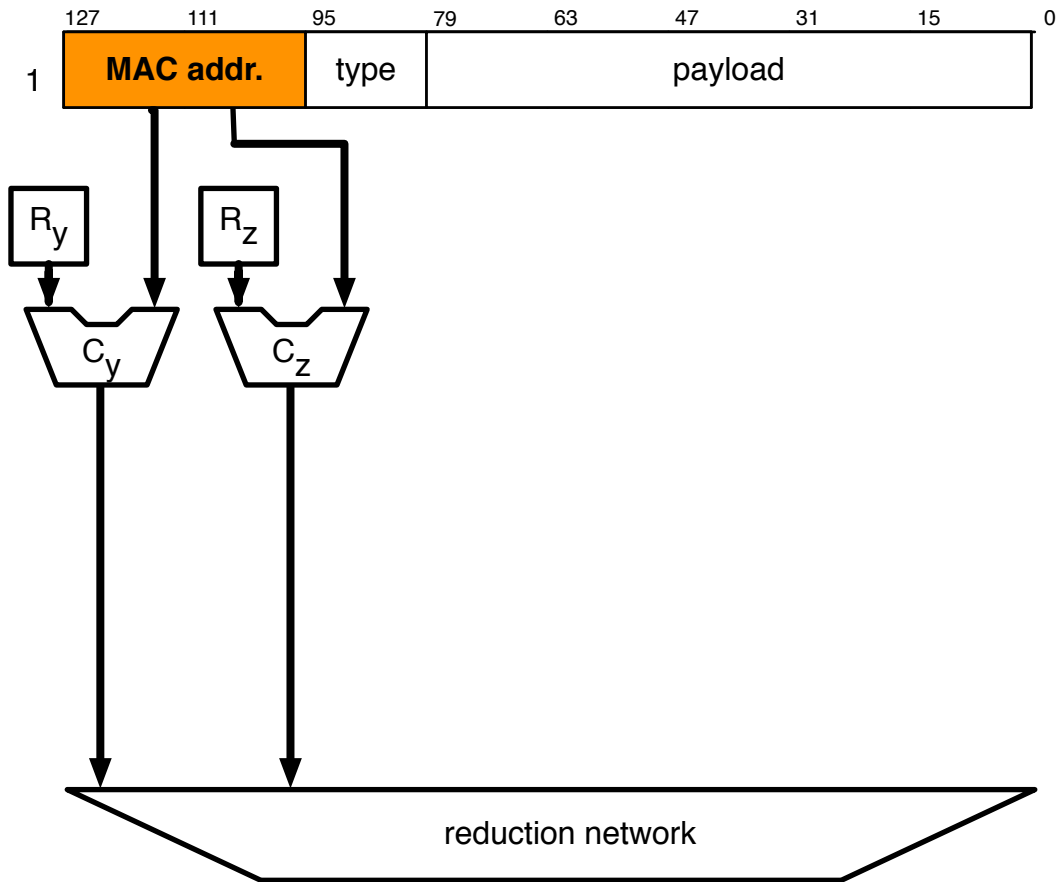

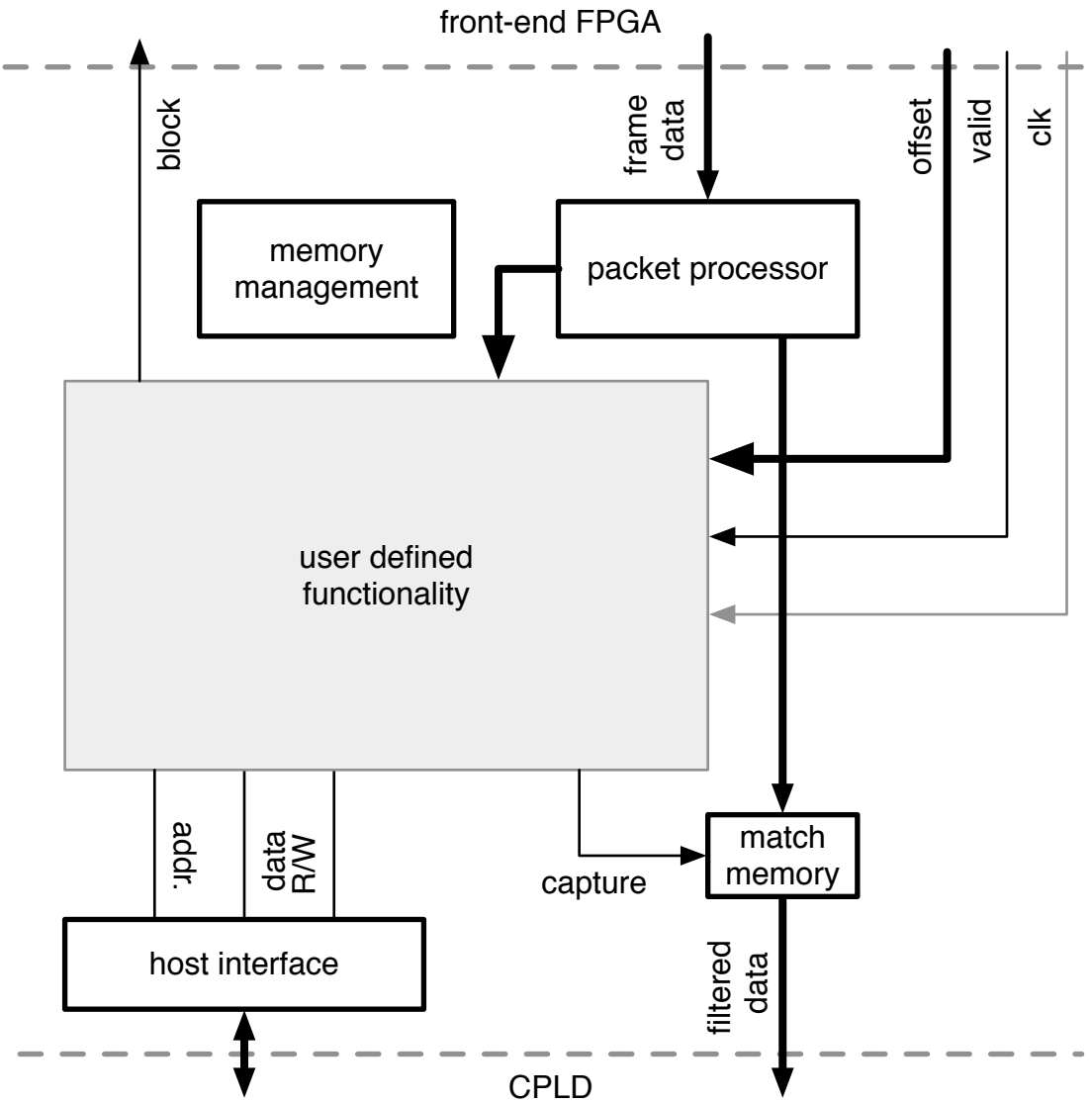

front-end FPGA

frame data

offset

valid

clk

frame data register

R_0

R_1

R_n

C_0

C_1

C_n

reduction network

counter

host interface

CPLD

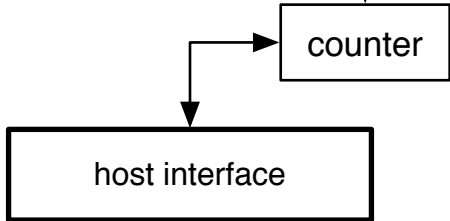
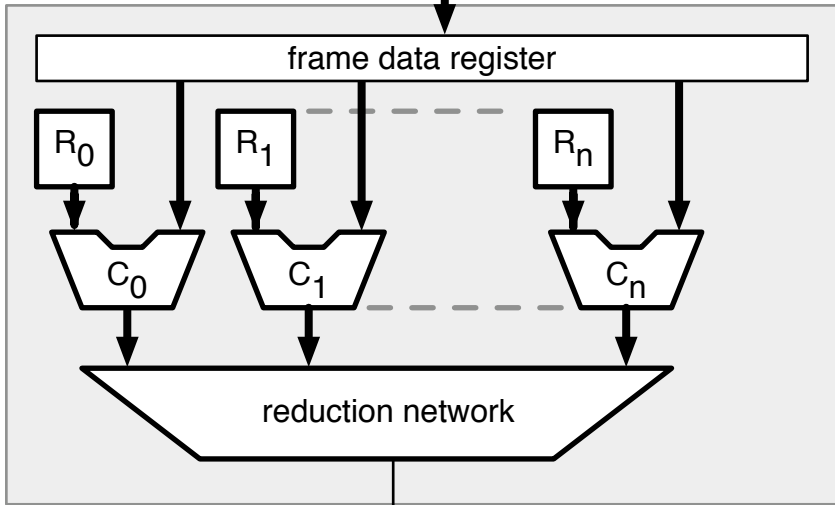

front-end FPGA

frame data

offset

valid

clk

frame data register

R_0

R_1

R_n

C_0

C_1

C_n

reduction network

counter

host interface

CPLD

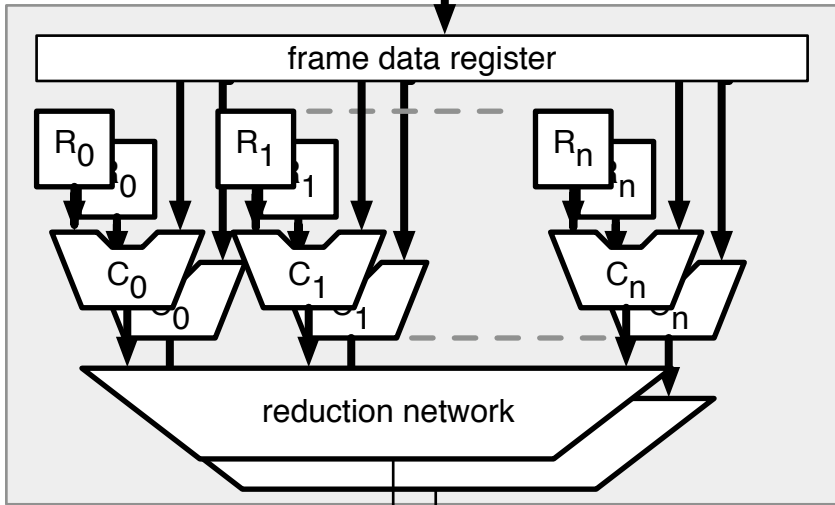

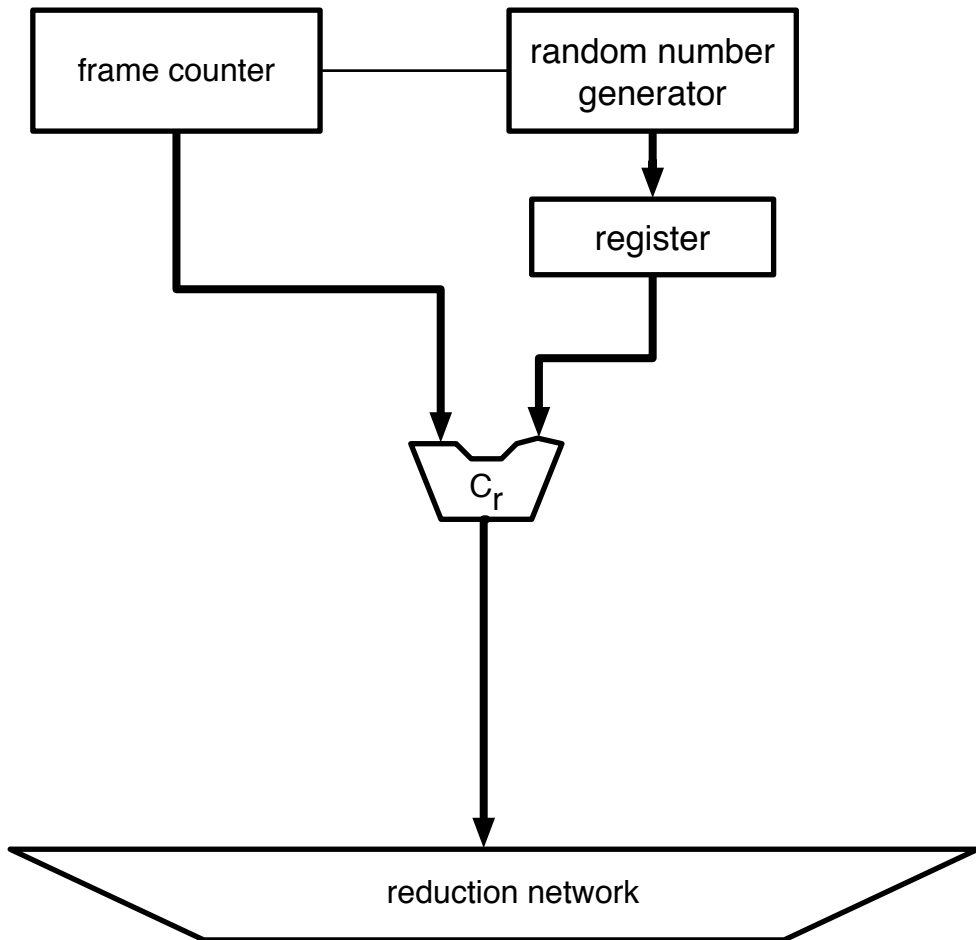

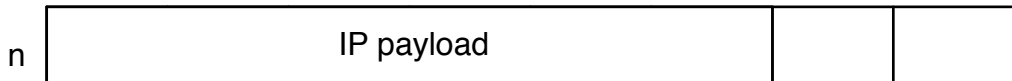
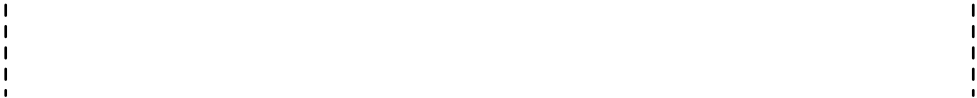
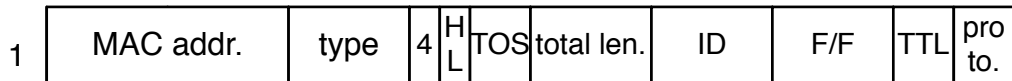
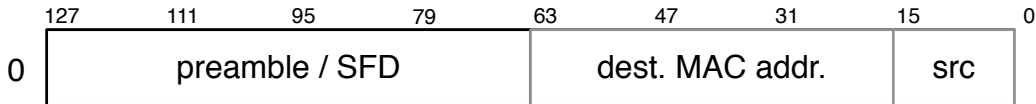

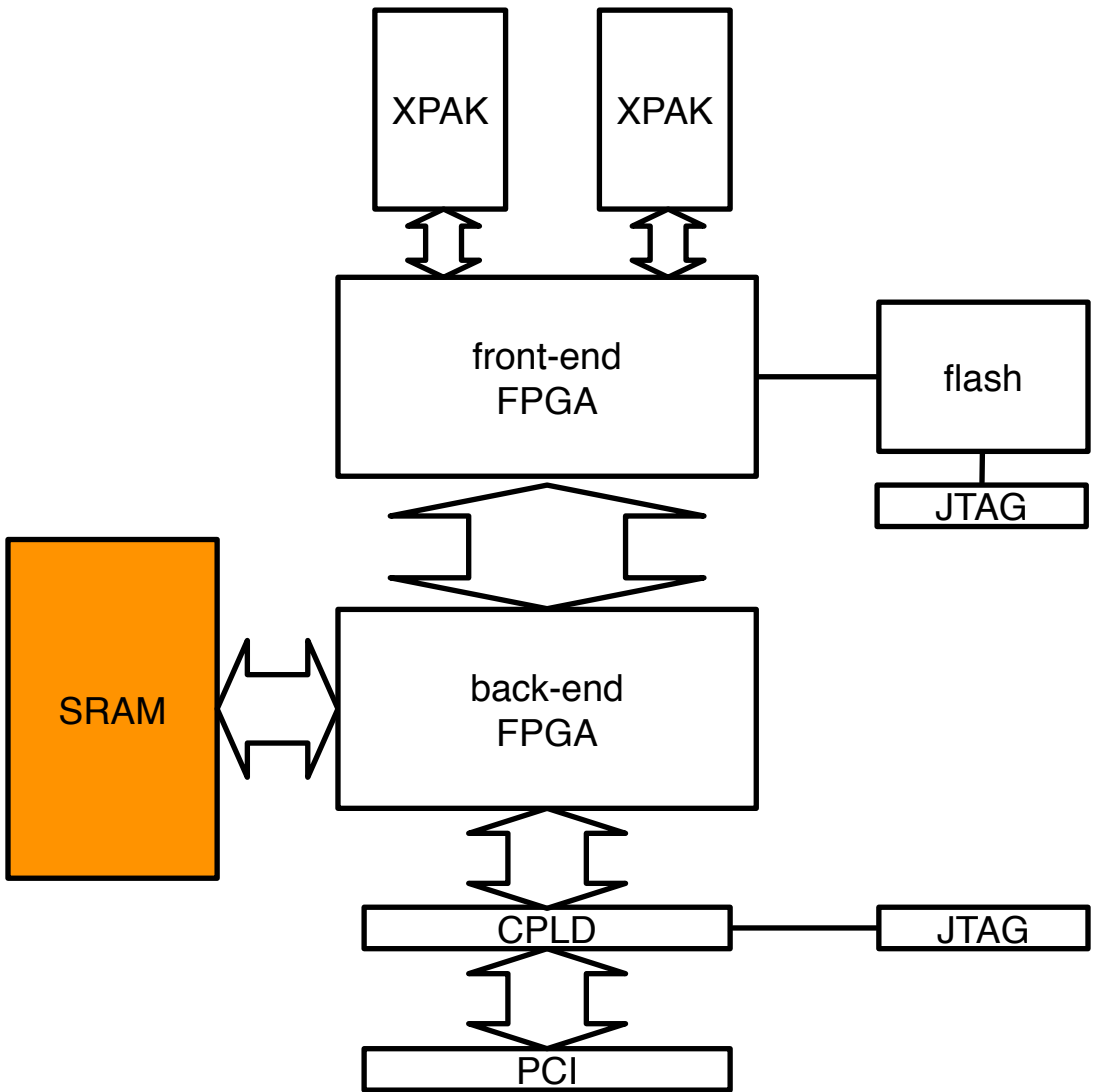

Thank you for your attention