

A Hackers Approach To Building Electric Guitars



Arne Rick (couchsofa)

couchsofa.tumblr.com

cptrick@jabber.ccc.de

cptrick999@gmail.com

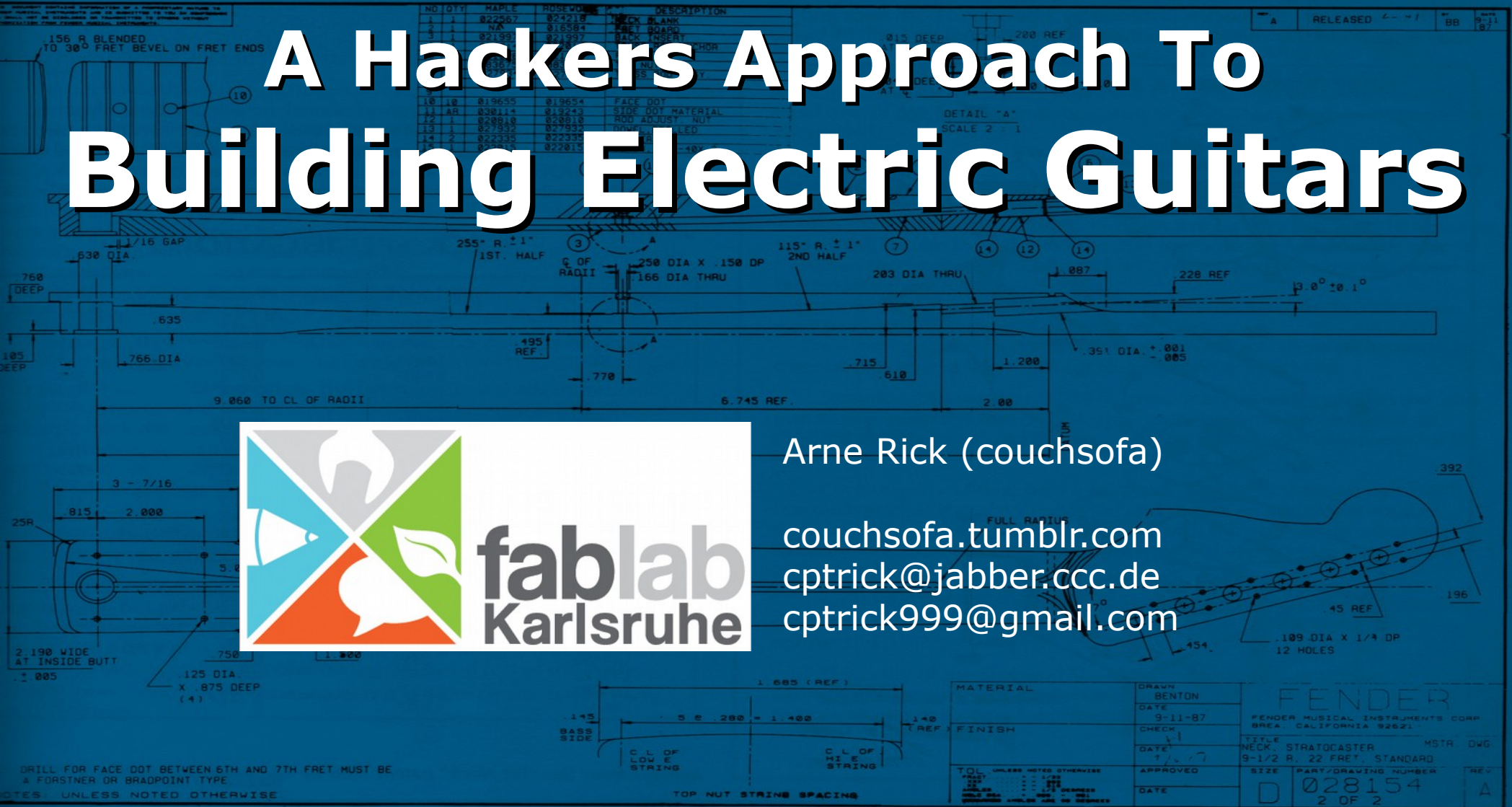

MATERIAL		DRAWN	FENDER	
FINISH		BENTON	MSTR DWG	
TOL UNLESS NOTED OTHERWISE		DATE	FENDER MUSICAL INSTRUMENTS CORP	
.001		9-11-87	BREA CALIFORNIA 92621	
.002		CHECK	TITLE	
.005		1	NECK, STRATOCASTER	
.010		DATE	9-1/2 R. 22 FRET, STANDARD	
.015		APPROVED	SIZE	PART/DRAWING NUMBER
.020		DATE	D	028154
.030				2 OF 2
.040				A

NOTES: UNLESS NOTED OTHERWISE

TOP NUT STRING SPACING

Background

- Civil/Constructive Engineering
- Cologne/Aachen → Karlsruhe
- FabLab Karlsruhe

- Photography
- uC/Arduino
- C64
- Computational Theory
- LangSec

Contact

Arne Rick (Couchsofa)
#rackmonkey #fablab-ka (freenode)
#alug (ircnet)
#dsi (saphirjd.me)

@CouchSofa
cptrick@jabber.ccc.de
cptrick999@gmail.com

Background
What? Why?

@einball has a problem!

- Awesome Bass/Guitar
- Custom Design
- Control entire manufacturing process
- DIY all the way
- ...
- From Scratch
- Learn

Background
What? Why?

Tools

- Bandsaw
- Plane



Background
What? Why?

Tools

- Bandsaw
- Plane
- Rasp



Background
What? Why?

Tools

- Bandsaw
- Plane
- Rasp
- Clamps



Background
What? Why?

Tools

- Bandsaw
- Plane
- Rasp
- Clamps
- Router

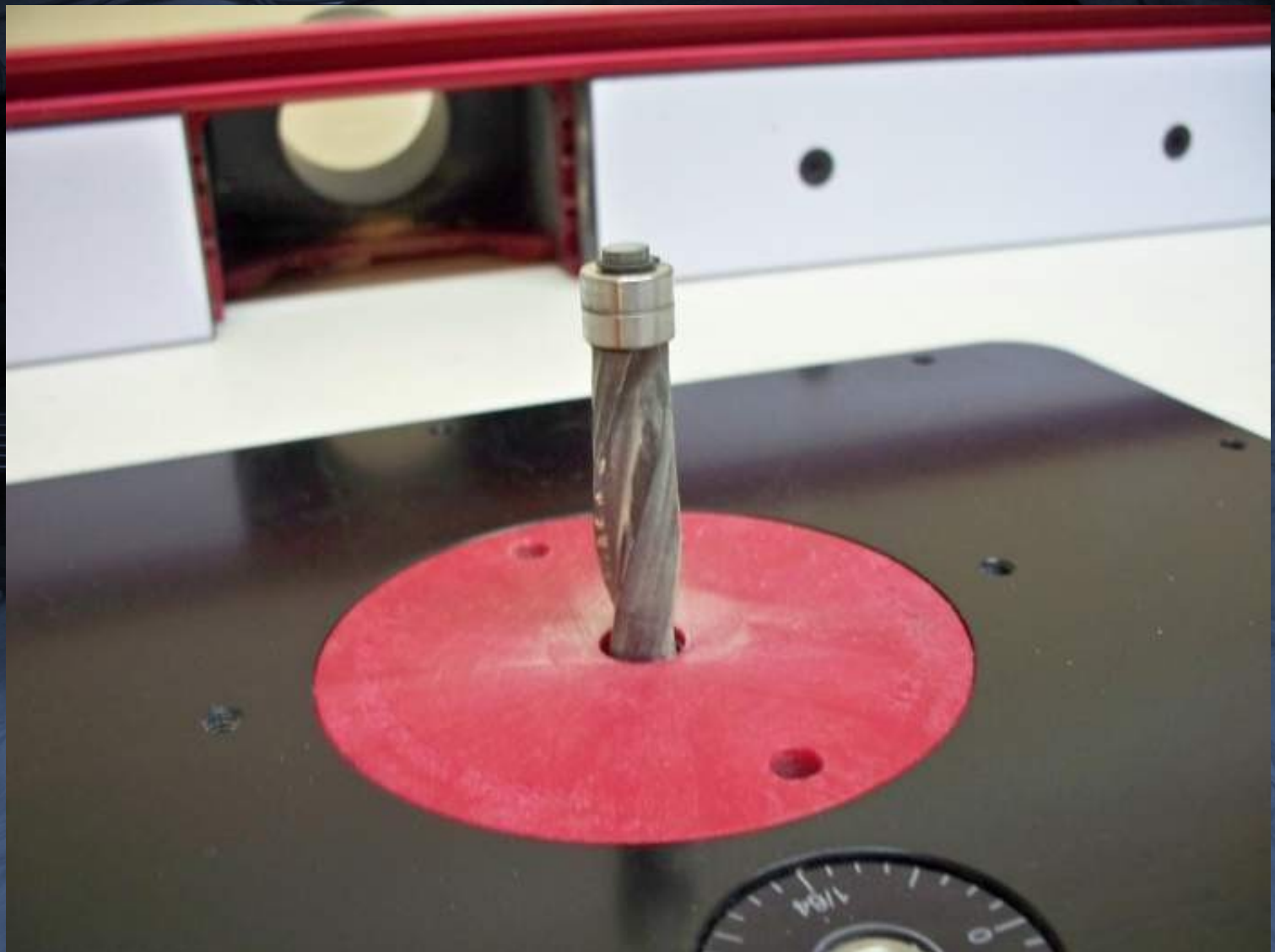

Background
What? Why?

Tools

- Bandsaw
- Plane
- Rasp
- Clamps
- Router
- CNC



Background
What? Why?

Tools

- Bandsaw
- Plane
- Rasp
- Clamps
- Router
- CNC
- 3D Printer
- Lathe

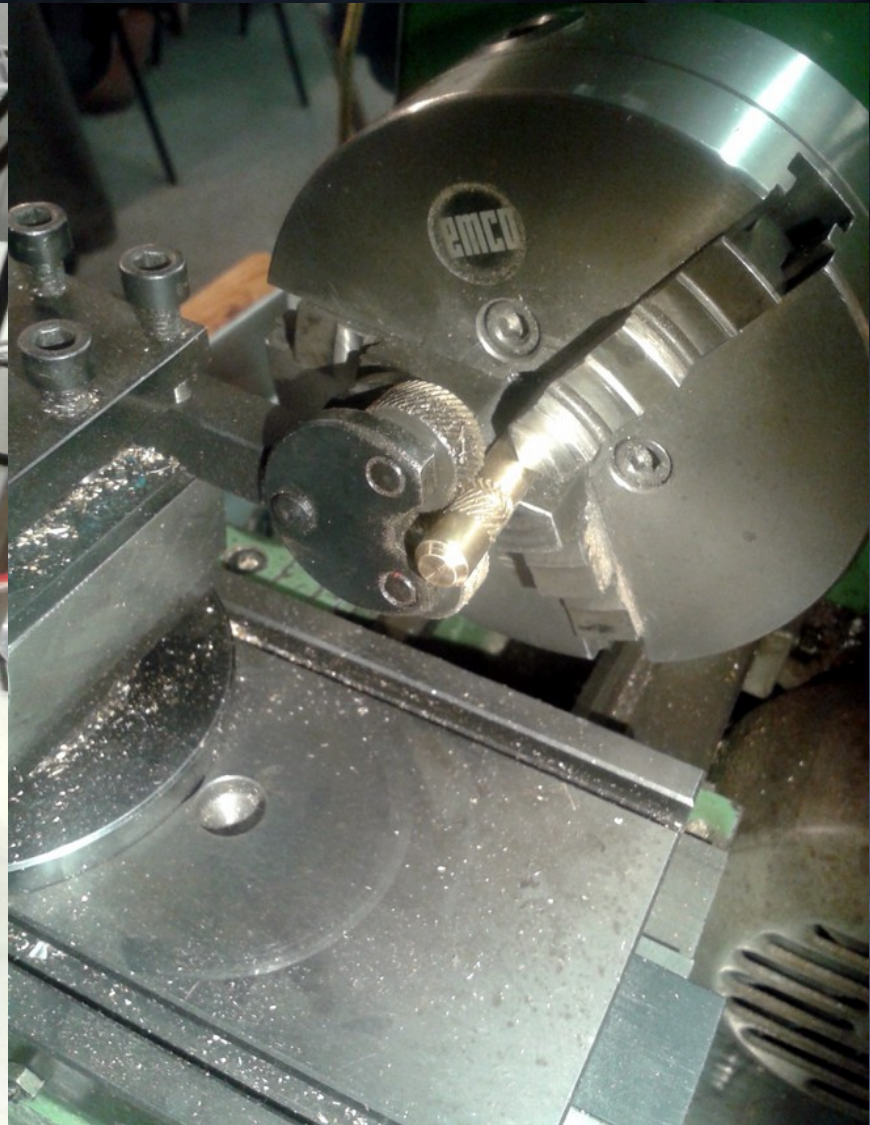
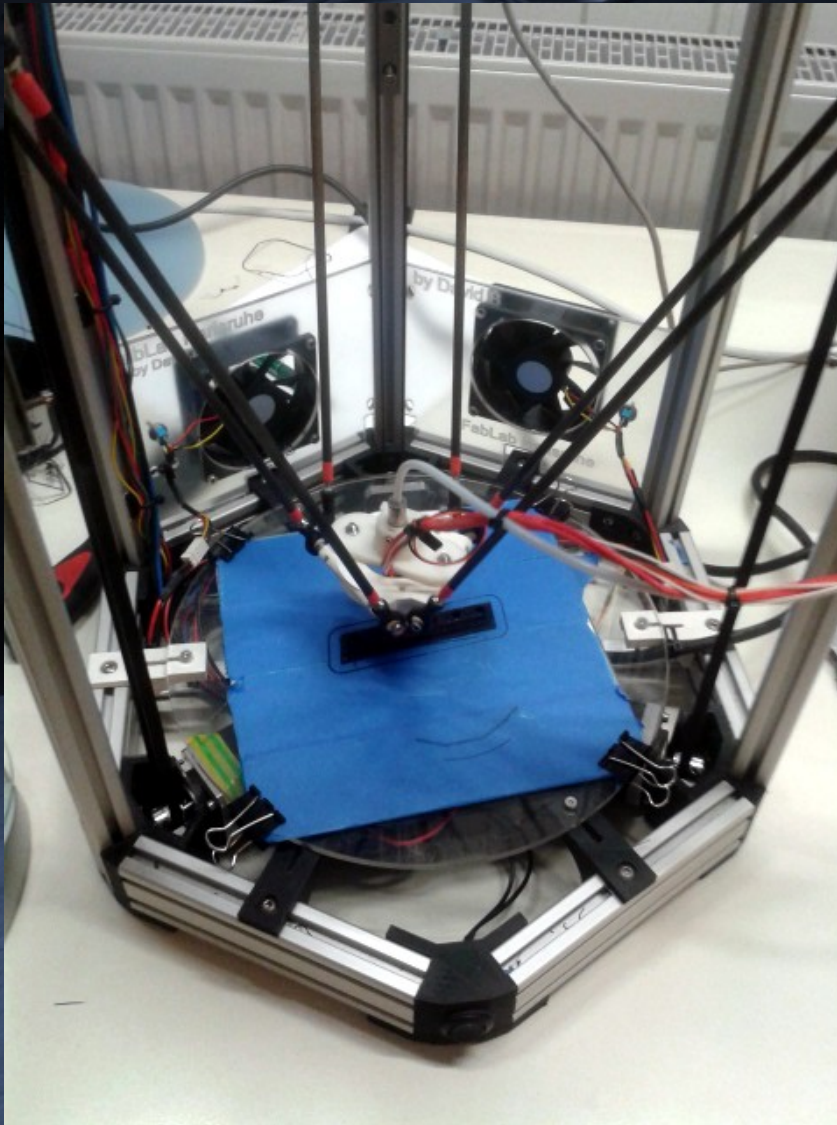

Background
What? Why?
Tools
Wood



Background
What? Why?
Tools
Wood

· Requirements

Moisture content: $\sim 5\%$ (ca. 1yr/2cm)

No faults (Knotholes, Insects, ...)

„Hardwoods“: ρ , f_k , long grain, dense annual rings, ...

Measurements:

Body: 35 x 55 x 5 cm

Neck: 70 – 100 x 8 x 3 cm

Fingerboard: 50 – 70 x 8 x 0,8 cm



Background
What? Why?

Tools

Wood

- Requirements
- Milling

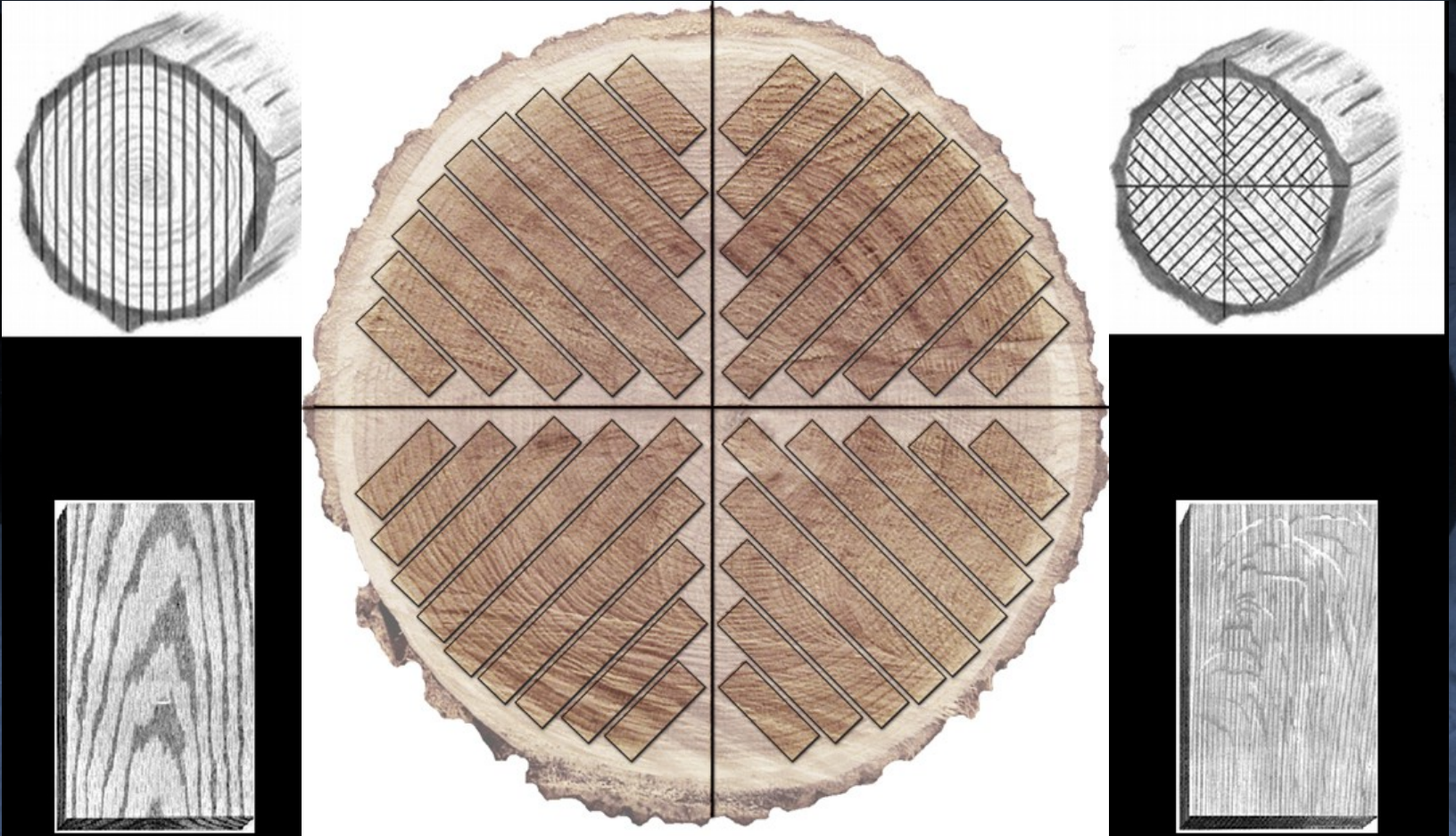

Let's get started



Hardware

- Tuning → Tension
- String Spacing
- Action
- Fix Strings

- Bridge
- Nut
- Tuner

- Headpiece/Nut
- Bridge/Tuner

Hardware

- Tuner
- Milling



Hardware

- Tuner
- Milling

```
#<wp_length> = [93.8 - #<bevel> + 2.5]
#<steps> = [#<depth> / #<z-feed> * 0.5]
G00 X0 Y0 Z[#<z-safe>]
G00 Y[#<wp_length> * 0.5 + #<toolrad> - [#<bevel> + #<toolrad>]] X[#<wp_width> * 0.5 + #<toolrad>]
#<current_depth> = [#<depth>]
O101 repeat [#<steps>]
    #<current_depth> = [#<current_depth> - #<z-feed>]
    G01 Z[#<current_depth> - 2] F[#<feedrate>]
    G03 X[#<wp_width> * 0.5 + #<toolrad> - [#<bevel> + #<toolrad>]] Y[#<wp_length> * 0.5 + #<toolrad>]
    I[[#<bevel> + #<toolrad>] * -1] F[#<feedrate>]
    G01 X[#<wp_width> * -0.5 - #<toolrad> + [#<bevel> + #<toolrad>]] F[#<feedrate>]
    G03 X[#<wp_width> * -0.5 - #<toolrad>] Y[#<wp_length> * 0.5 + #<toolrad> - [#<bevel> + #<toolrad>]]
    J[[#<bevel> + #<toolrad>] * -1] F[#<feedrate>]
    #<current_depth> = [#<current_depth> - #<z-feed>]
    G01 Z[#<current_depth> - 2] F[#<feedrate>]
    G02 X[#<wp_width> * -0.5 - #<toolrad> + [#<bevel> + #<toolrad>]] Y[#<wp_length> * 0.5 + #<toolrad>]
    I[[#<bevel> + #<toolrad>]] F[#<feedrate>]
    G01 X[#<wp_width> * 0.5 + #<toolrad> - [#<bevel> + #<toolrad>]] F[#<feedrate>]
    G02 Y[#<wp_length> * 0.5 + #<toolrad> - [#<bevel> + #<toolrad>]] X[#<wp_width> * 0.5 + #<toolrad>]
    J[[#<bevel> + #<toolrad>] * -1] F[#<feedrate>]
O101 endrepeat
G00 Z[#<z-safe>]
(Return to Origin)
G00 X0 Y0 Z[#<z-safe>]
```



Hardware

- Tuner
- Milling
- Knobs

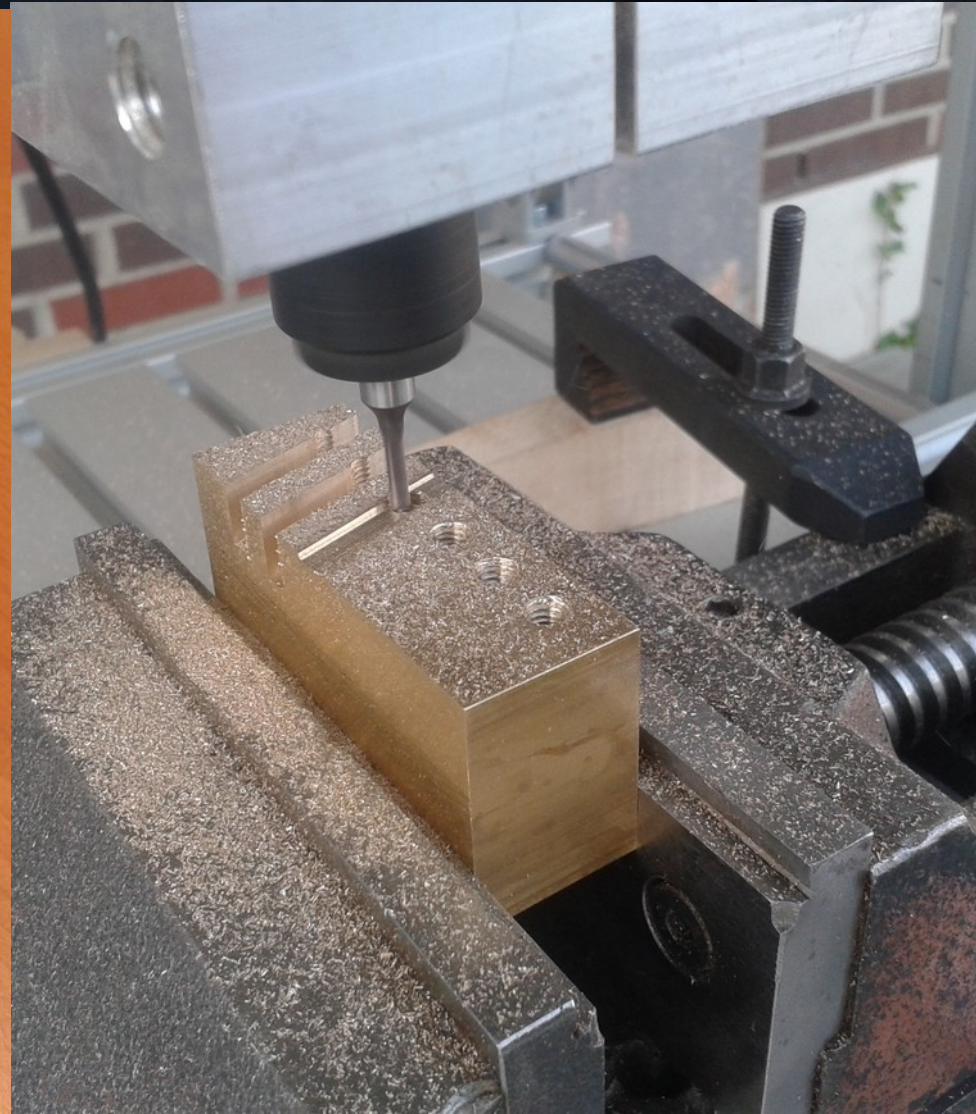
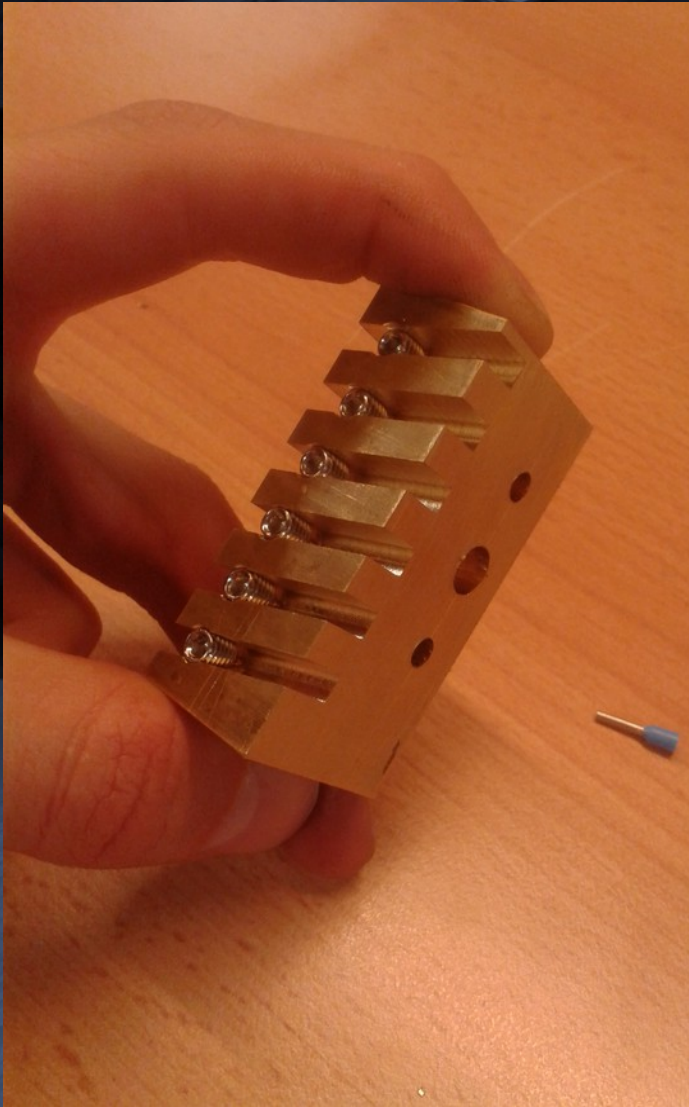

Hardware

- Tuner
- Milling
- Knobs
- Headpiece



Hardware

- Tuner
- Milling
- Knobs
- Headpiece

```
0101 repeat [#<strings>]

    G00 Z[#<z-safe>]

    #<current_depth> = 0

    0102 repeat [#<steps>]

        #<current_depth> =
        [#<current_depth> - #<z_feed>]

        G00 Y[5.900 +
        #<string_spacing> * #<n>] X[-7.150]
        F[#<feed>]

        G01 Z[#<current_depth>]
        F[#<z_feed_rate>]

        G02 Y[5.900 +
        #<string_spacing> * #<n>] X[-7.150]
        I[0.950] F[#<feed>]

    0102 endrepeat

    #<n> = [#<n> + 1]

0101 endrepeat

G00 Z[#<z-safe>]
G00 X0 Y0
```

```
0101 repeat [#<strings>]

    G00 Z[#<z-safe>]

    #<current_depth> = 0

    0102 repeat [#<steps>]

        #<current_depth> = [#<current_depth> -
        #<z_feed>]

        G00 Y[10.440 + #<string_spacing> * #<n>]
        X[13.148] F[#<feed>]

        G01 Z[#<current_depth>] F[#<z_feed_rate>]

        G01 Y[3.354 + #<string_spacing> * #<n>] X[-
        13.148] F[#<feed>]

        G01 Y[4.694 + #<string_spacing> * #<n>]
        F[#<feed>]

        G01 Y[11.740 + #<string_spacing> * #<n>]
        X[13.148] F[#<feed>]

    0102 endrepeat

    #<n> = [#<n> + 1]

0101 endrepeat

G00 Z[#<z-safe>]
G00 X0 Y0
```

Hardware

- Tuner
- Milling
- Knobs
- Headpiece
- Assembly

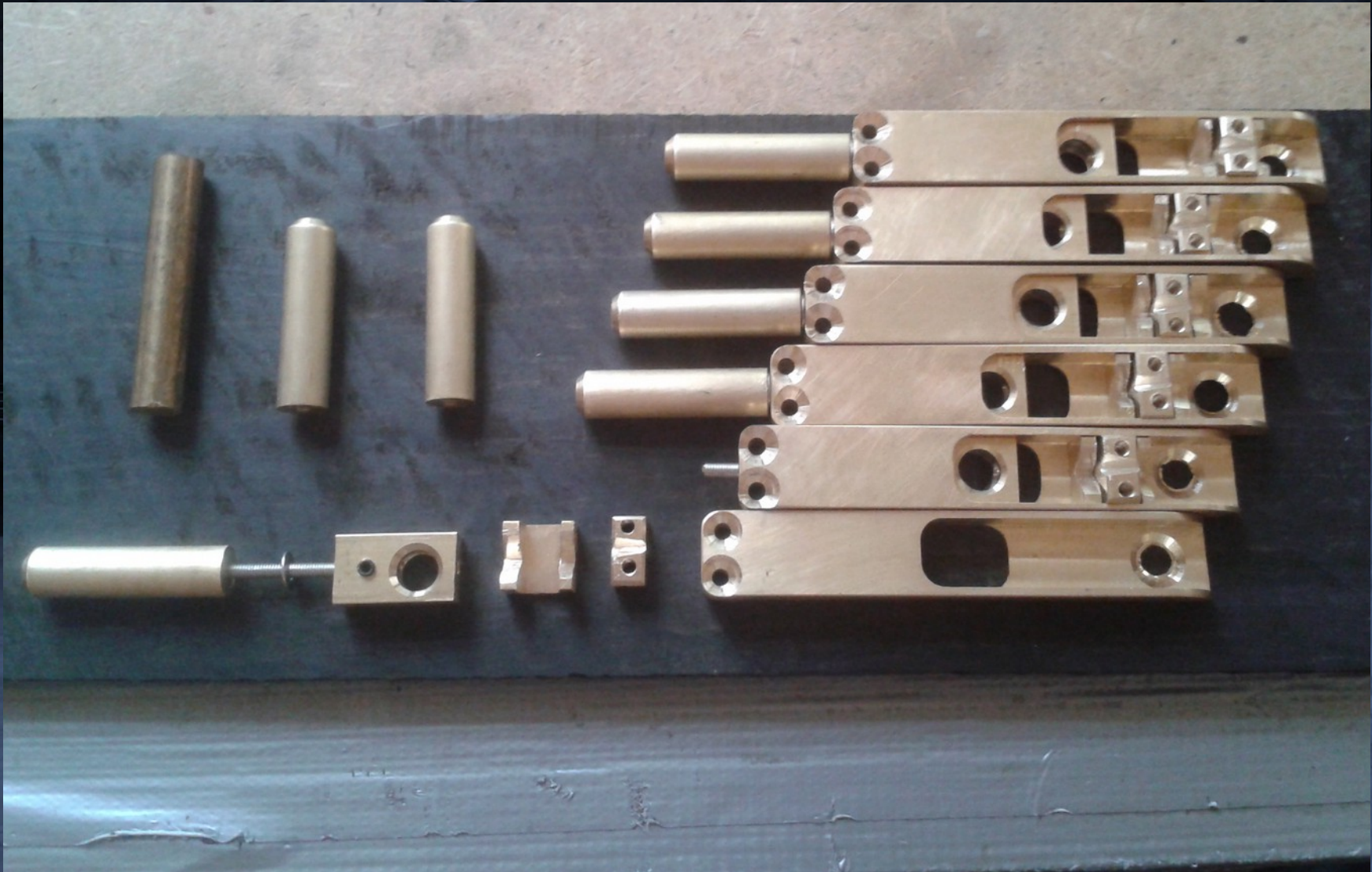

Hardware
Neck



Hardware
Neck

- Laminates

Laminates

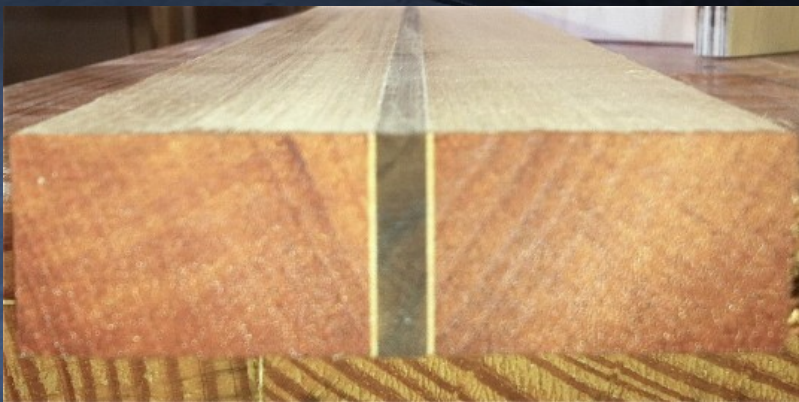
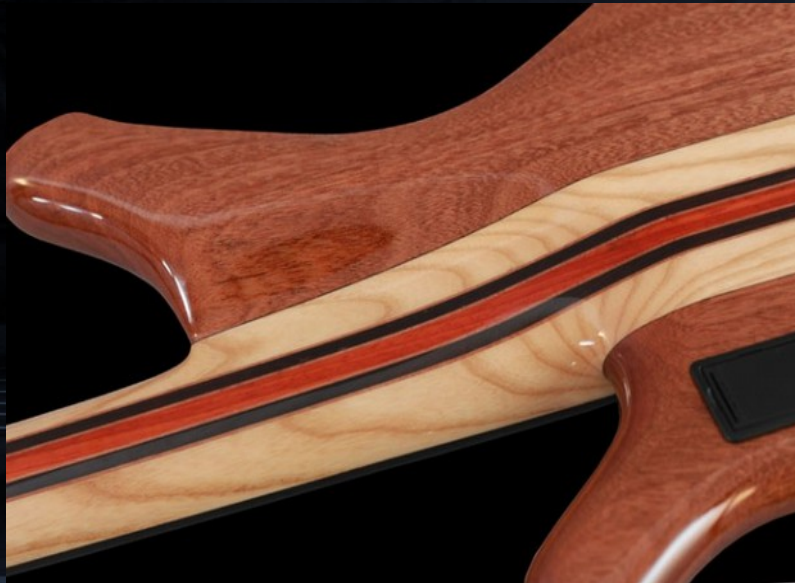

Hardware
Neck

- Laminates
- Truss Rod

Truss Rod

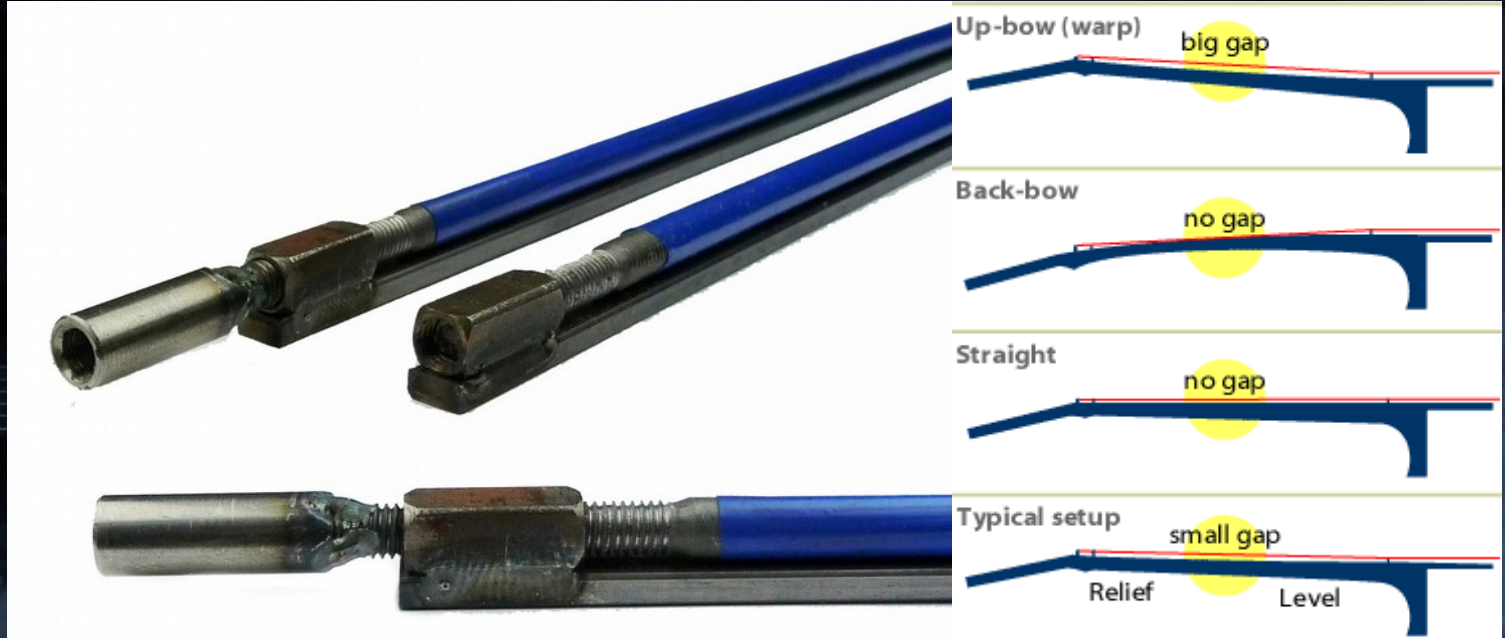

Hardware
Neck

- Laminates
- Truss Rod
- Vintage Truss Rod

Vintage Truss Rod

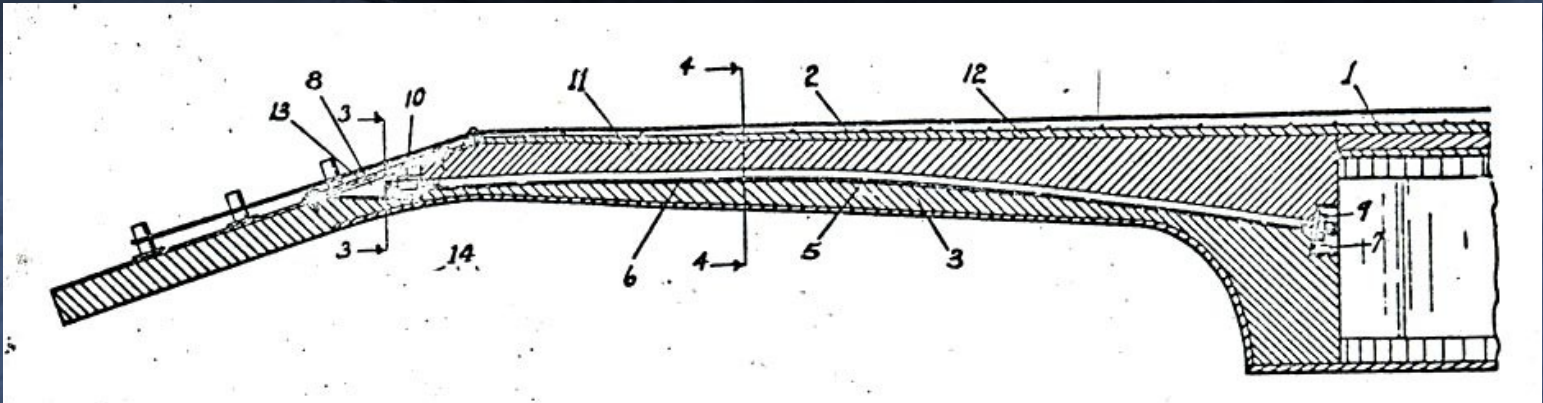

Hardware Neck

- Laminates
- Truss Rod
- Vintage Truss Rod
- Carbon Rods

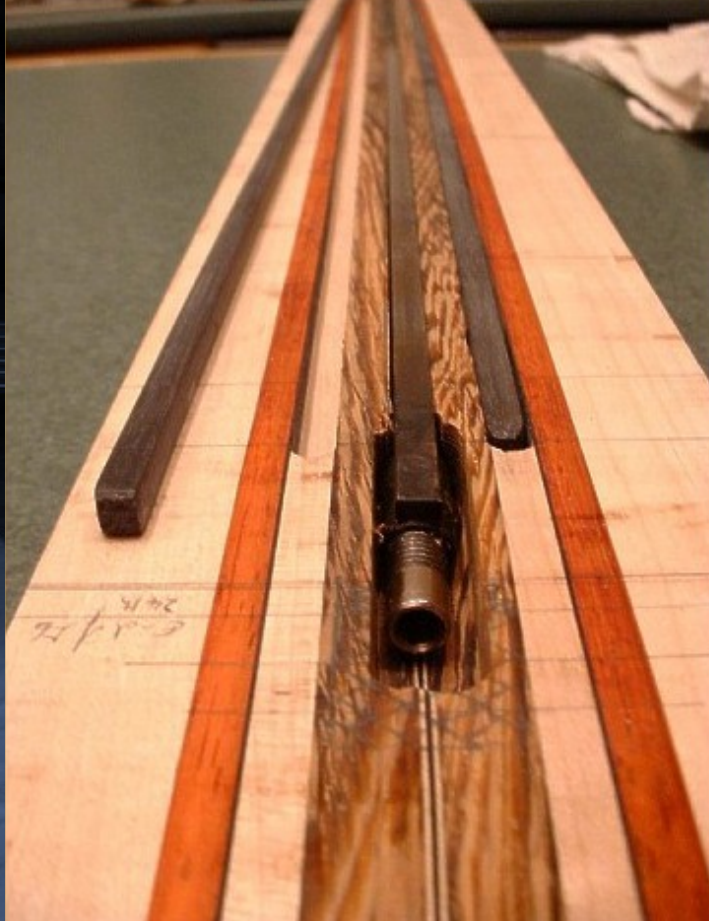

Carbon Rods

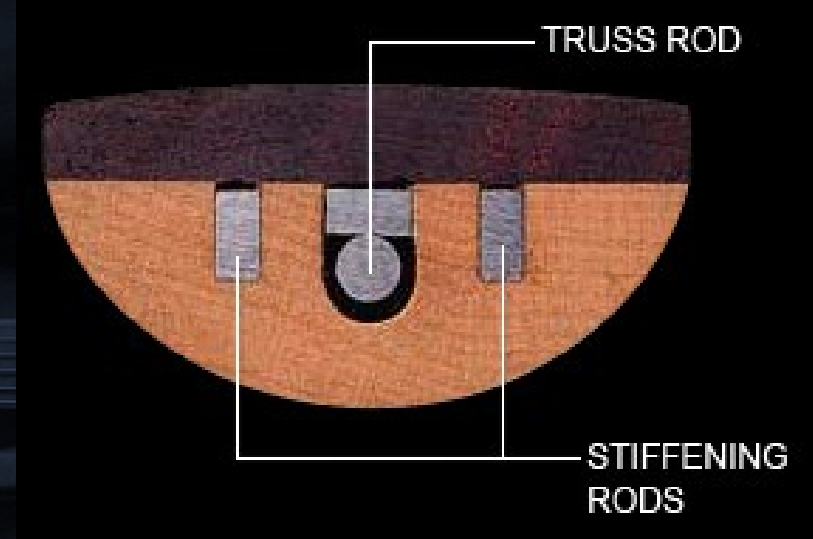

Hardware
Neck

- Laminates
- Truss Rod
- Vintage Truss Rod
- Carbon Rods
- Flat Headstock

Flat Head

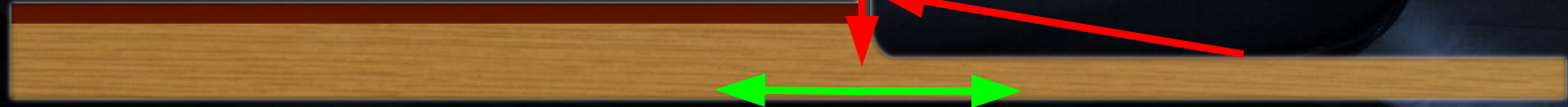

Hardware Neck

- Laminates
- Truss Rod
- Vintage Truss Rod
- Carbon Rods
- Flat Headstock

Flat Head

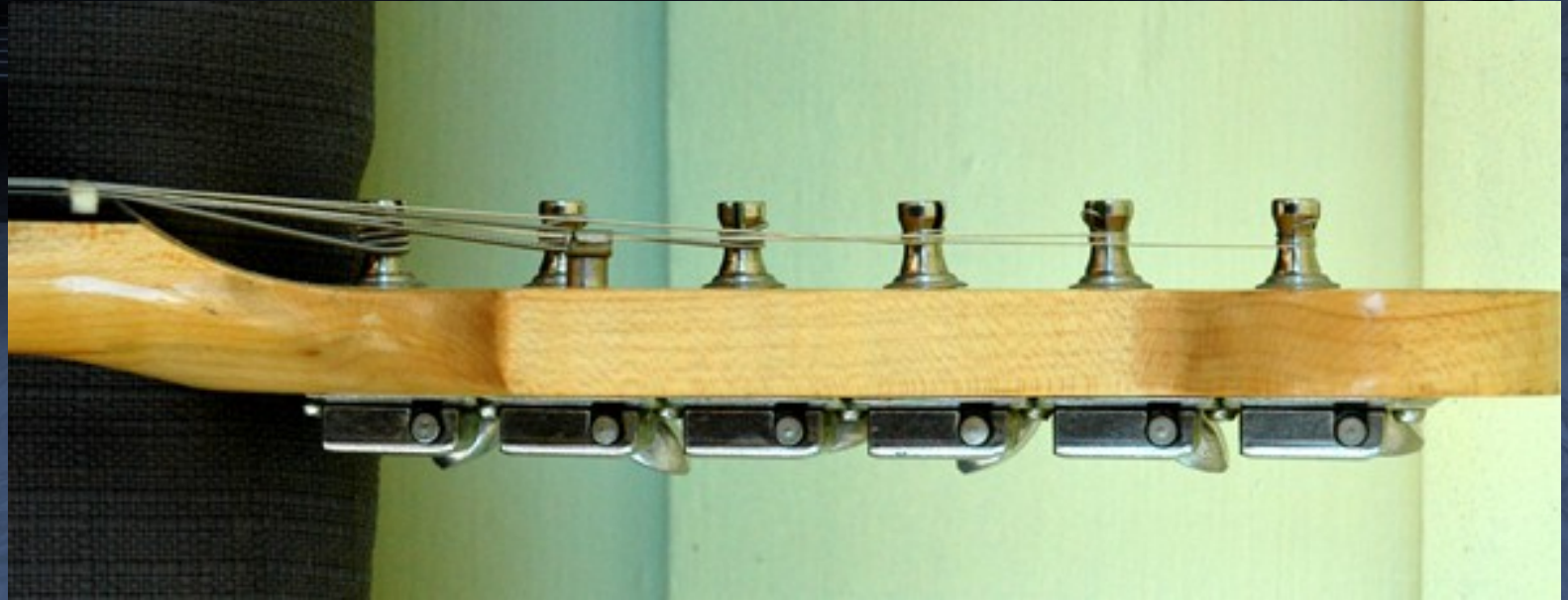
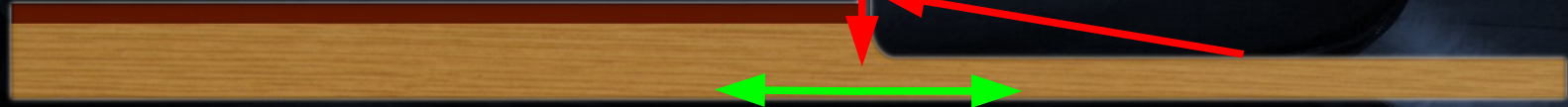

Hardware Neck

- Laminates
- Truss Rod
- Vintage Truss Rod
- Carbon Rods
- Flat Headstock

Break Angle



Hardware Neck

- Laminates
- Truss Rod
- Vintage Truss Rod
- Carbon Rods
- Flat Headstock
- Angled Headstock

Angled Headstock

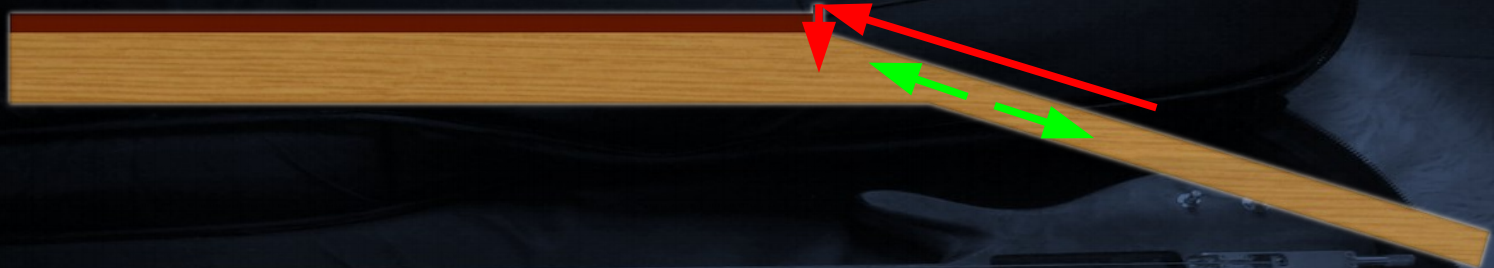

Hardware Neck

- Laminates
- Truss Rod
- Vintage Truss Rod
- Carbon Rods
- Flat Headstock
- Angled Headstock

Angled Headstock

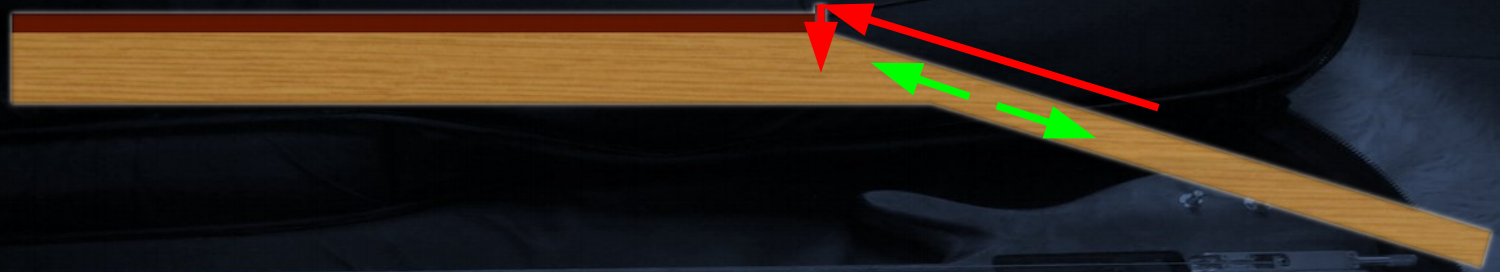

Hardware
Neck

- Laminates
- Truss Rod
- Vintage Truss Rod
- Carbon Rods
- Flat Headstock
- Angled Headstock
- Scarf Joint

Scarf Joint



Hardware Neck

- Laminates
- Truss Rod
- Vintage Truss Rod
- Carbon Rods
- Flat Headstock
- Angled Headstock
- Scarf Joint

Scarf Joint



Hardware Neck

- Laminates
- Truss Rod
- Vintage Truss Rod
- Carbon Rods
- Flat Headstock
- Angled Headstock
- Scarf Joint

Scarf Joint



Hardware
Neck

- Laminates
- Truss Rod
- Vintage Truss Rod
- Carbon Rods
- Flat Headstock
- Angled Headstock
- Scarf Joint
- Volute

Volute

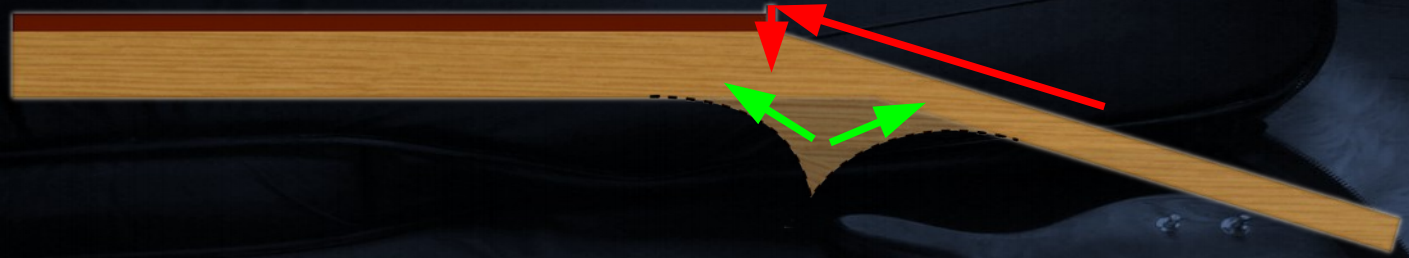

Hardware Neck

- Laminates
- Truss Rod
- Vintage Truss Rod
- Carbon Rods
- Flat Headstock
- Angled Headstock
- Scarf Joint
- Volute

Volute

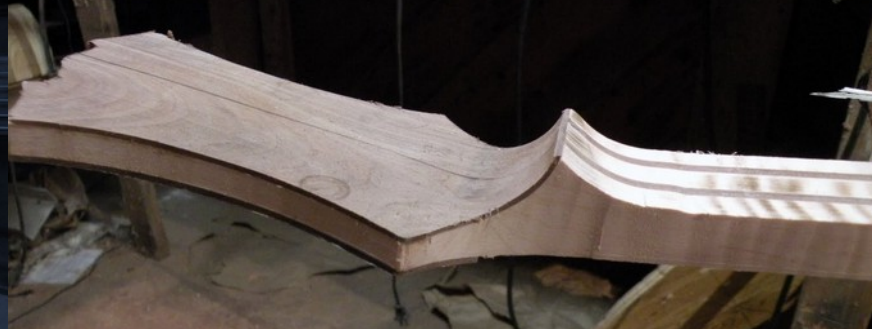

Hardware Neck

- Laminates
- Truss Rod
- Vintage Truss Rod
- Carbon Rods
- Flat Headstock
- Angled Headstock
- Scarf Joint
- Volute
- **Headless**

Headless



Hardware

Neck

- Laminates
- Truss Rod
- Vintage Truss Rod
- Carbon Rods
- Flat Headstock
- Angled Headstock
- Scarf Joint
- Volute
- Headless
- Interface

Interface



Hardware Neck

- Laminates
- Truss Rod
- Vintage Truss Rod
- Carbon Rods
- Flat Headstock
- Angled Headstock
- Scarf Joint
- Volute
- Headless
- Interface
- Radius

Radius



Hardware Neck

- Laminates
- Truss Rod
- Vintage Truss Rod
- Carbon Rods
- Flat Headstock
- Angled Headstock
- Scarf Joint
- Volute
- Headless
- Interface
- Radius
- Compound Radius

Compound Radius



Hardware Neck

- Laminates
- Truss Rod
- Vintage Truss Rod
- Carbon Rods
- Flat Headstock
- Angled Headstock
- Scarf Joint
- Volute
- Headless
- Interface
- Radius
- Compound Radius

Compound Radius



Hardware

Neck

- Laminates
- Truss Rod
- Vintage Truss Rod
- Carbon Rods
- Flat Headstock
- Angled Headstock
- Scarf Joint
- Volute
- Headless
- Interface
- Radius
- Compound Radius
- Scales

Scales

L

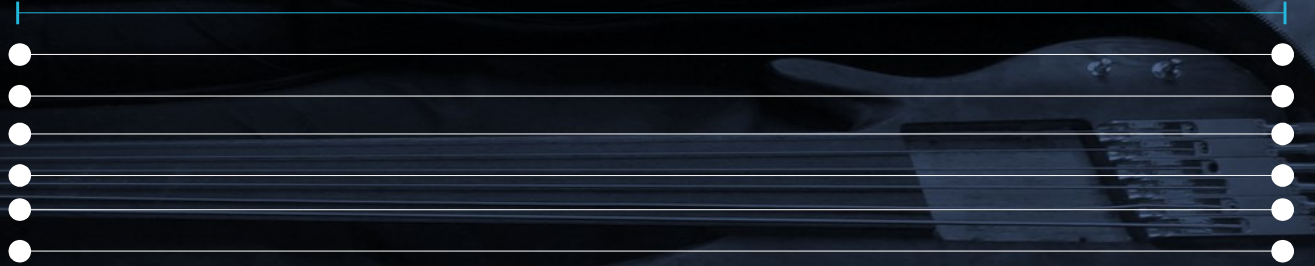

Hardware Neck

- Laminates
- Truss Rod
- Vintage Truss Rod
- Carbon Rods
- Flat Headstock
- Angled Headstock
- Scarf Joint
- Volute
- Headless
- Interface
- Radius
- Compound Radius
- Scales

Scales



Hardware
Neck

- Laminates
- Truss Rod
- Vintage Truss Rod
- Carbon Rods
- Flat Headstock
- Angled Headstock
- Scarf Joint
- Volute
- Headless
- Interface
- Radius
- Compound Radius
- Scales

Scales (Equal Temperament)

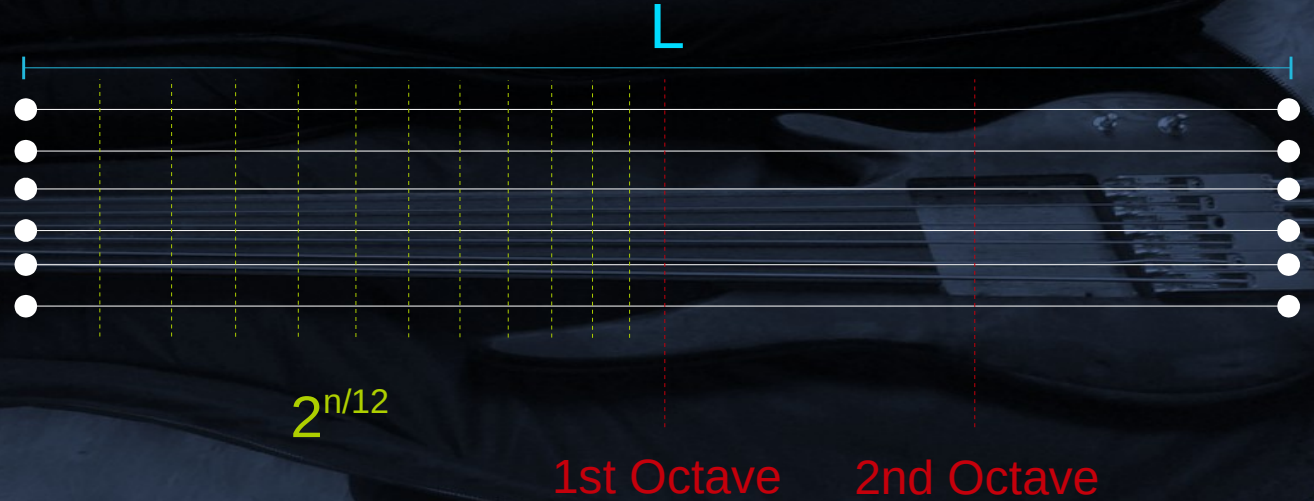

Hardware Neck

- Laminates
- Truss Rod
- Vintage Truss Rod
- Carbon Rods
- Flat Headstock
- Angled Headstock
- Scarf Joint
- Volute
- Headless
- Interface
- Radius
- Compound Radius
- Scales

Scales (Equal Temperament)

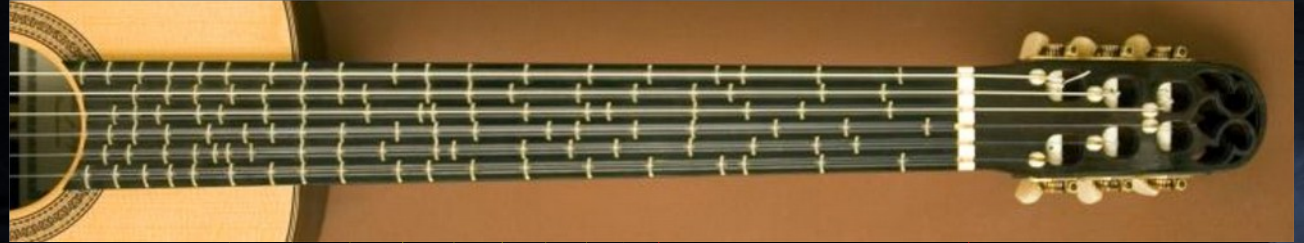

Hardware Neck

- Laminates
- Truss Rod
- Vintage Truss Rod
- Carbon Rods
- Flat Headstock
- Angled Headstock
- Scarf Joint
- Volute
- Headless
- Interface
- Radius
- Compound Radius
- Scales

Scales (Equal Temperament)

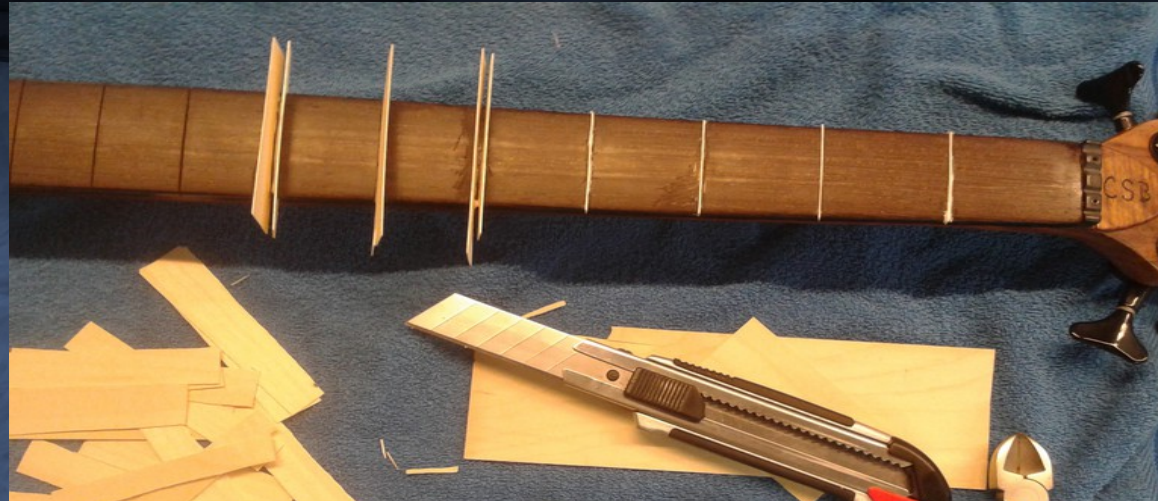

Hardware

Neck

- Laminates
- Truss Rod
- Vintage Truss Rod
- Carbon Rods
- Flat Headstock
- Angled Headstock
- Scarf Joint
- Volute
- Headless
- Interface
- Radius
- Compound Radius
- Scales
- Multiscale

$$f = \frac{\sqrt{\frac{T}{m/L}}}{2L}$$

Multiscale

C (40):	75 N	→
G (45):	214 N	→
D (60):	256 N	→
A' (90):	271 N	→
E' (105):	230 N	→
B'' (145):	207 N	→



Hardware Neck

- Laminates
- Truss Rod
- Vintage Truss Rod
- Carbon Rods
- Flat Headstock
- Angled Headstock
- Scarf Joint
- Volute
- Headless
- Interface
- Radius
- Compound Radius
- Scales
- Multiscale
- Contour

Contour



This is my neck profile.
There are many like it, but this one is mine.

Hardware Neck

- Laminates
- Truss Rod
- Vintage Truss Rod
- Carbon Rods
- Flat Headstock
- Angled Headstock
- Scarf Joint
- Volute
- Headless
- Interface
- Radius
- Compound Radius
- Scales
- Multiscale
- Contour



Contour



Hardware

Neck

Body

- Bolt-on / Neck-through

Body

Bolt-on vs Neck-through

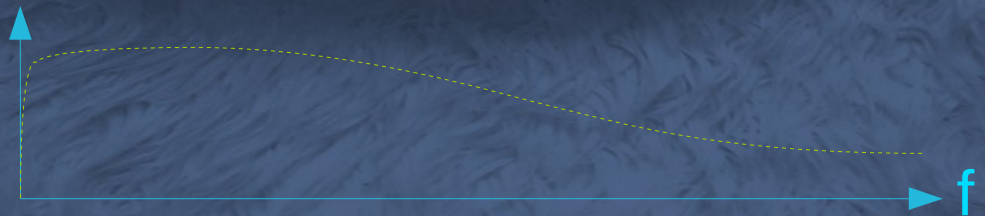
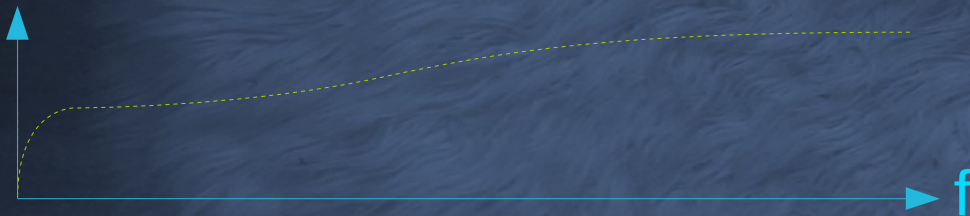

Hardware

Neck

Body

- Bolt-on / Neck-through
- **Solid**

Solid Body



Hardware

Neck

Body

- Bolt-on / Neck-through
- Solid
- Chambered

Chambered Body



Hardware

Neck

Body

- Bolt-on / Neck-through
- Solid
- Chambered
- **Hollow**

Hollow Body



Hardware

Neck

Body

- Bolt-on / Neck-through
- Solid
- Chambered
- Hollow
- Design

Design

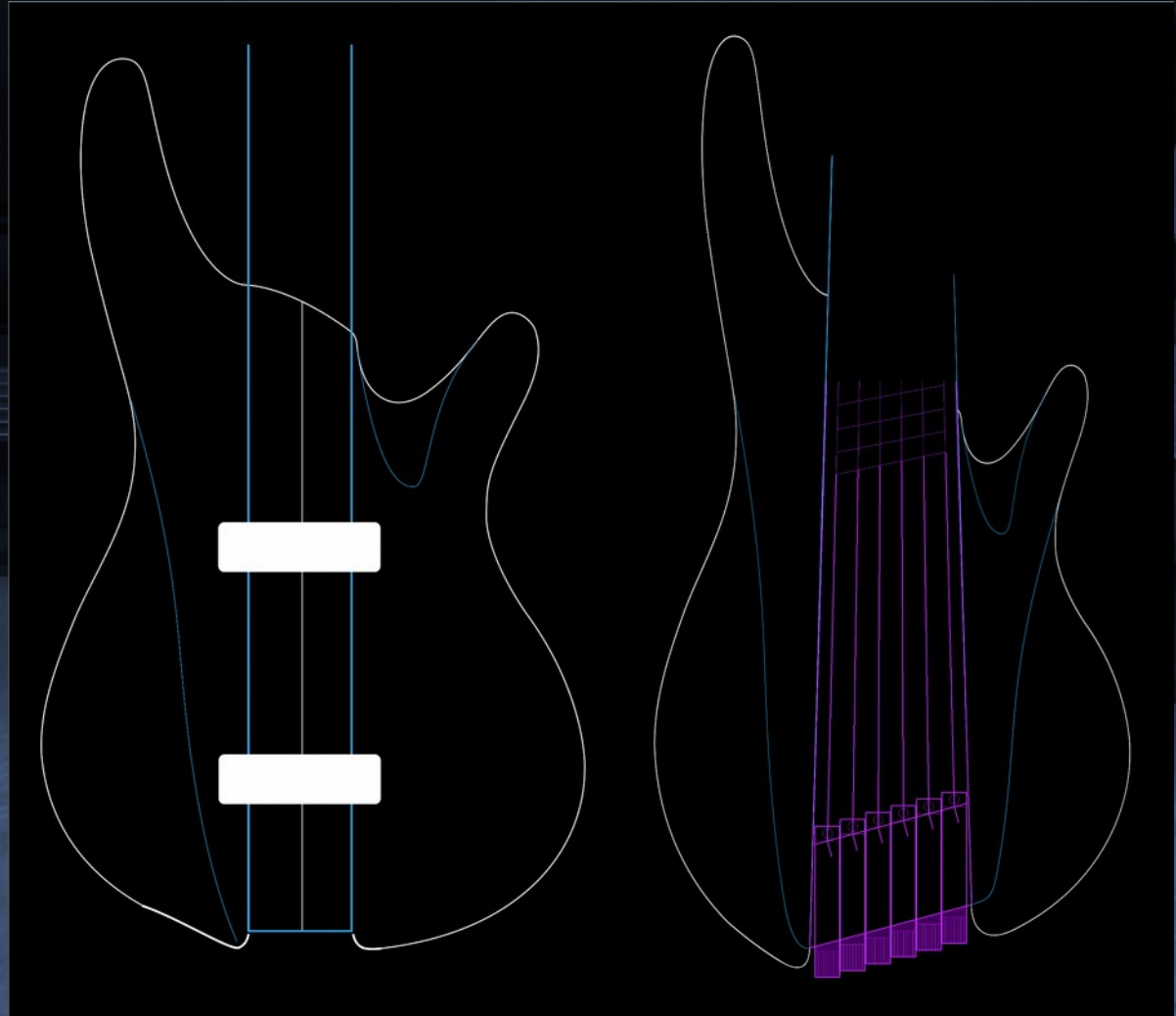

Hardware

Neck

Body

- Bolt-on / Neck-through
- Solid
- Chambered
- Hollow
- Design
- Templates

Design → Templates

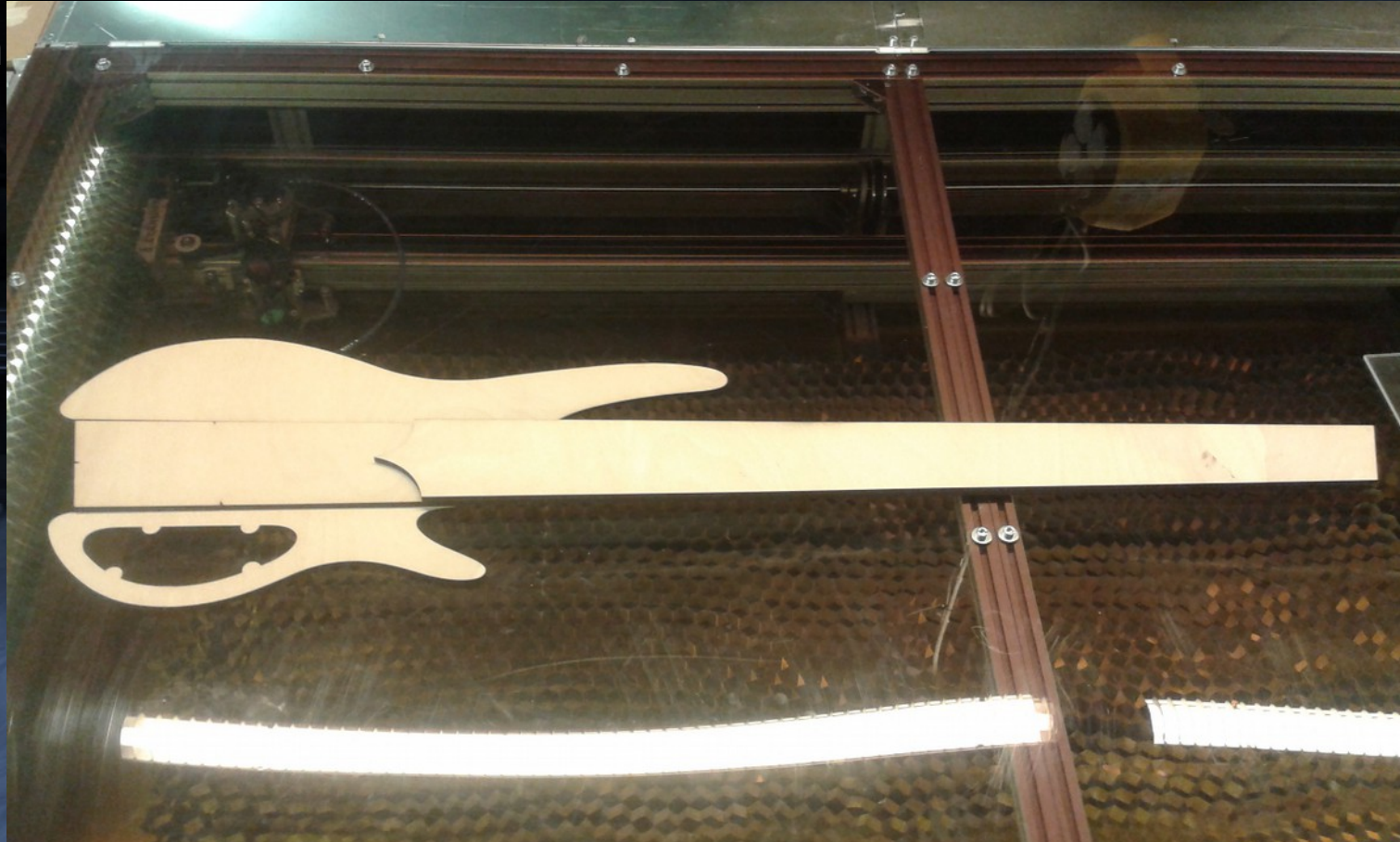

Hardware
Neck
Body

- Bolt-on / Neck-through
- Solid
- Chambered
- Hollow
- Design
- Templates
- Glue Up

Glue Up



Hardware
Neck
Body

- Bolt-on / Neck-through
- Solid
- Chambered
- Hollow
- Design
- Templates
- Glue Up
- Routing

Routing



Hardware
Neck
Body

- Bolt-on / Neck-through
- Solid
- Chambered
- Hollow
- Design
- Templates
- Glue Up
- Routing
- Glue Up

Glue Up



Hardware
Neck
Body
Electronics

Electronics

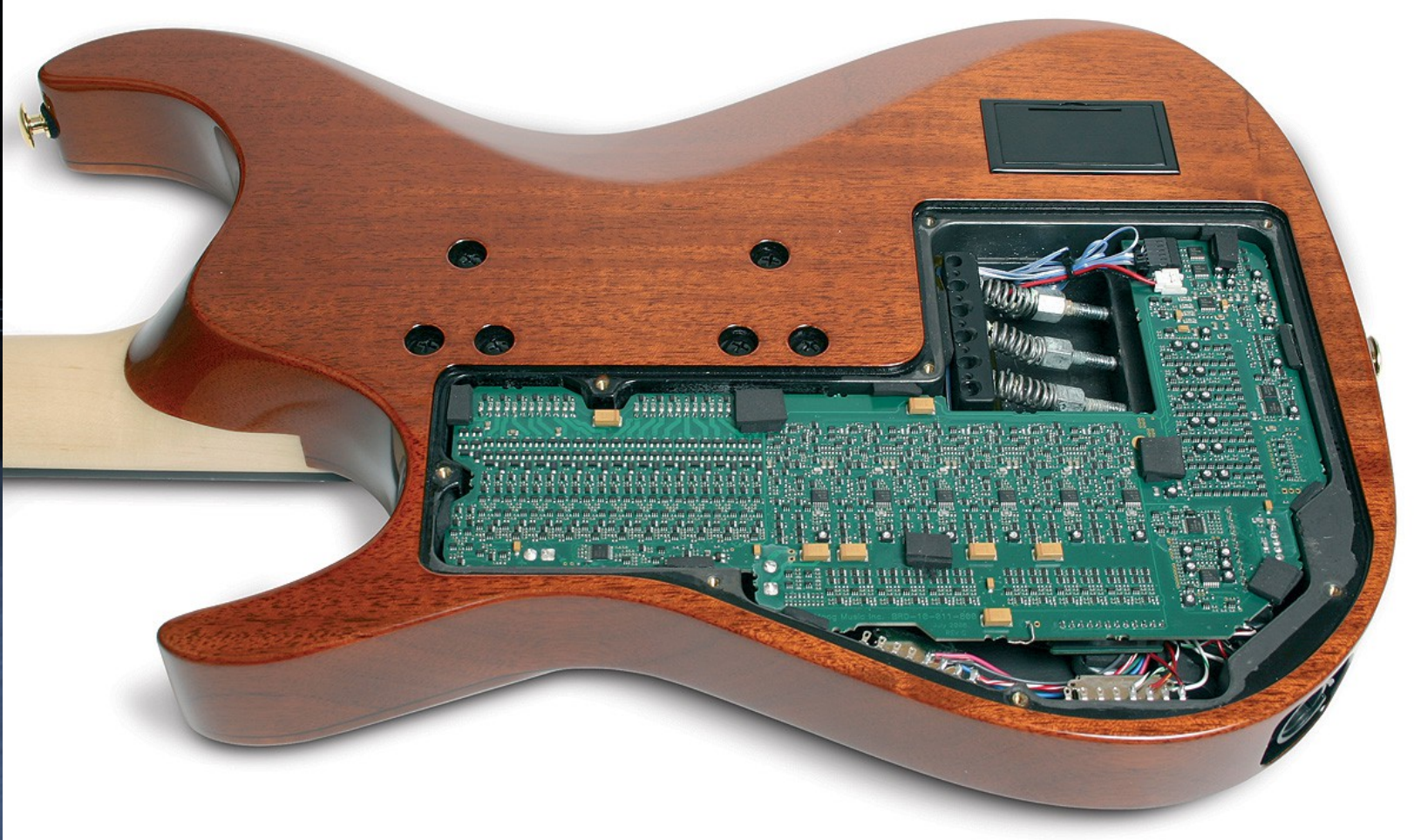

Hardware
Neck
Body
Electronics
· Active

Active

- Low Impedance (Buffer)
- Boost (EQ)

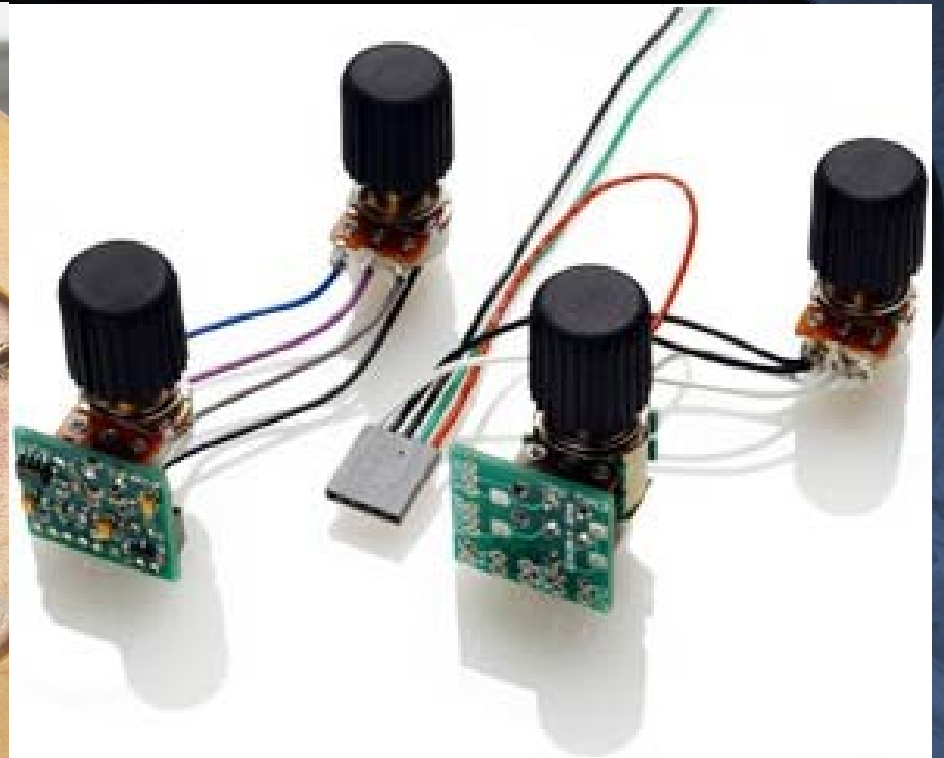
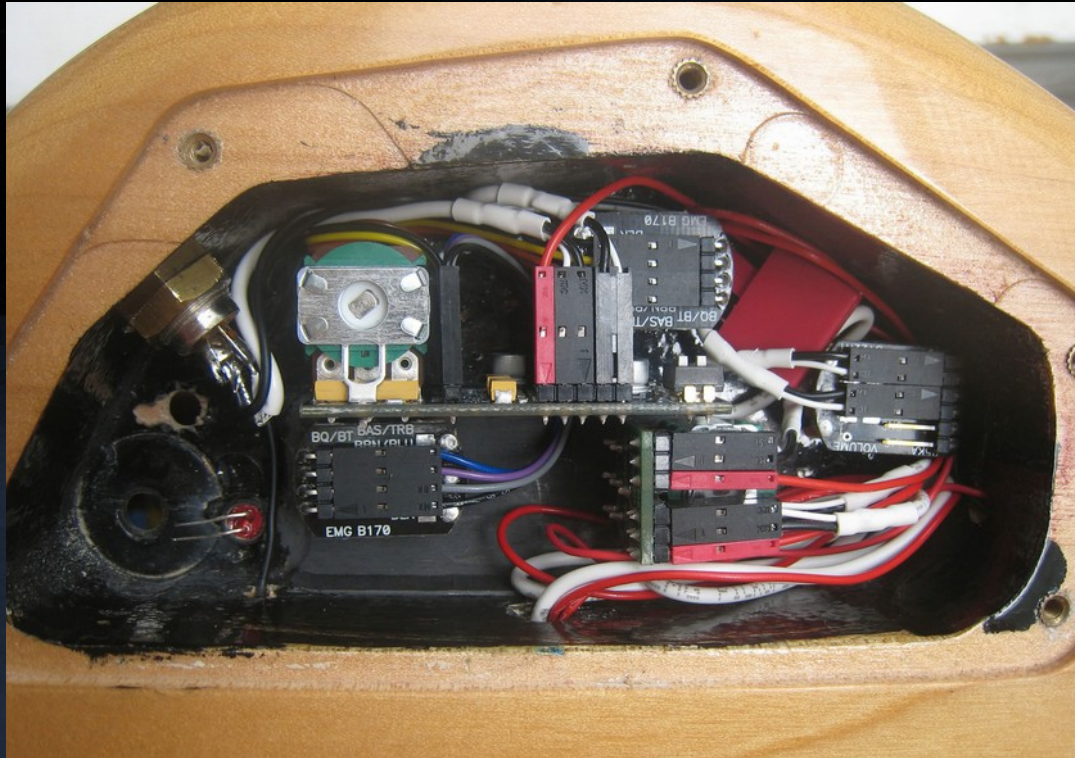

- Hardware
- Neck
- Body
- Electronics
 - Active
 - Passive

Passive

- High Impedance
- Only Cut (EQ)

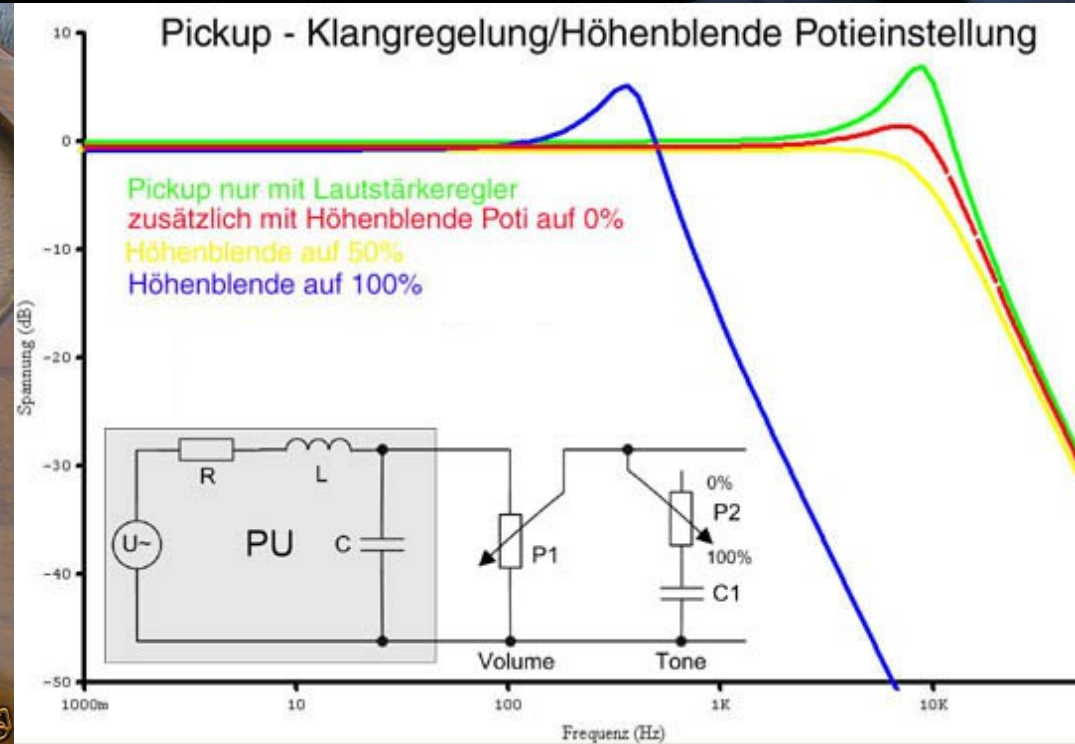
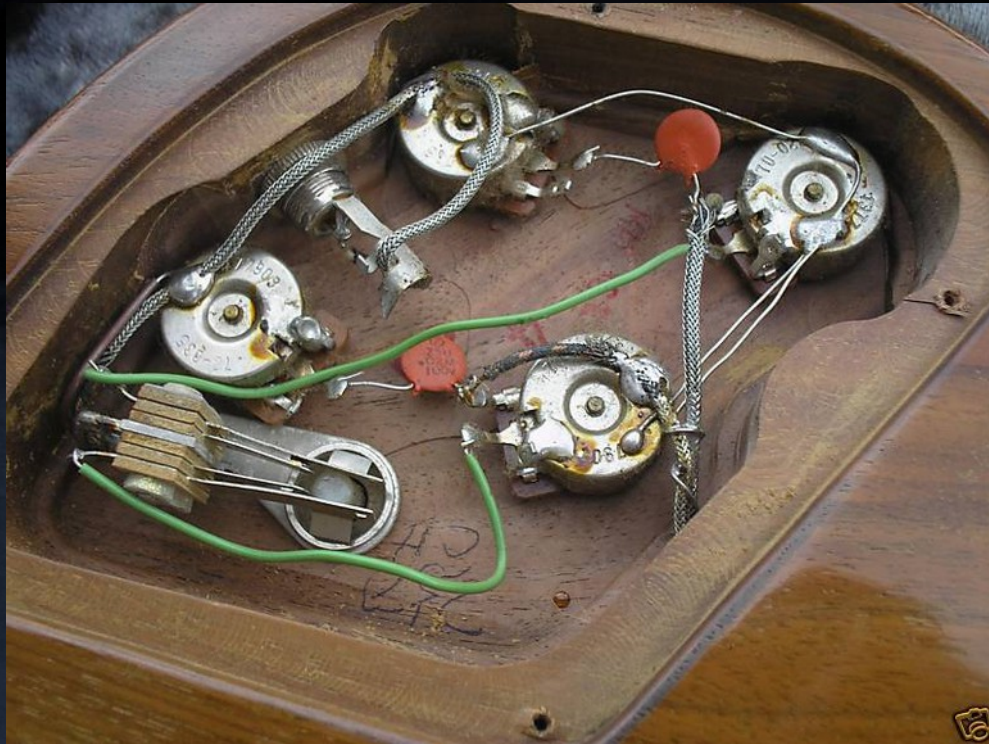

Hardware
Neck
Body
Electronics

- Active
- Passive
- Pickups

Pickups

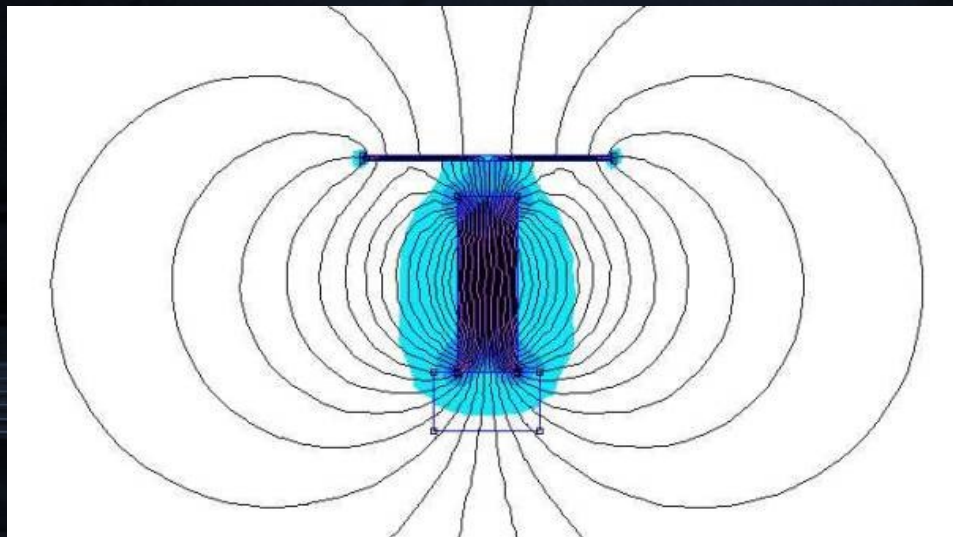

Hardware
Neck
Body

Electronics

- Active
- Passive
- Pickups
- Types

Optical / Piezo

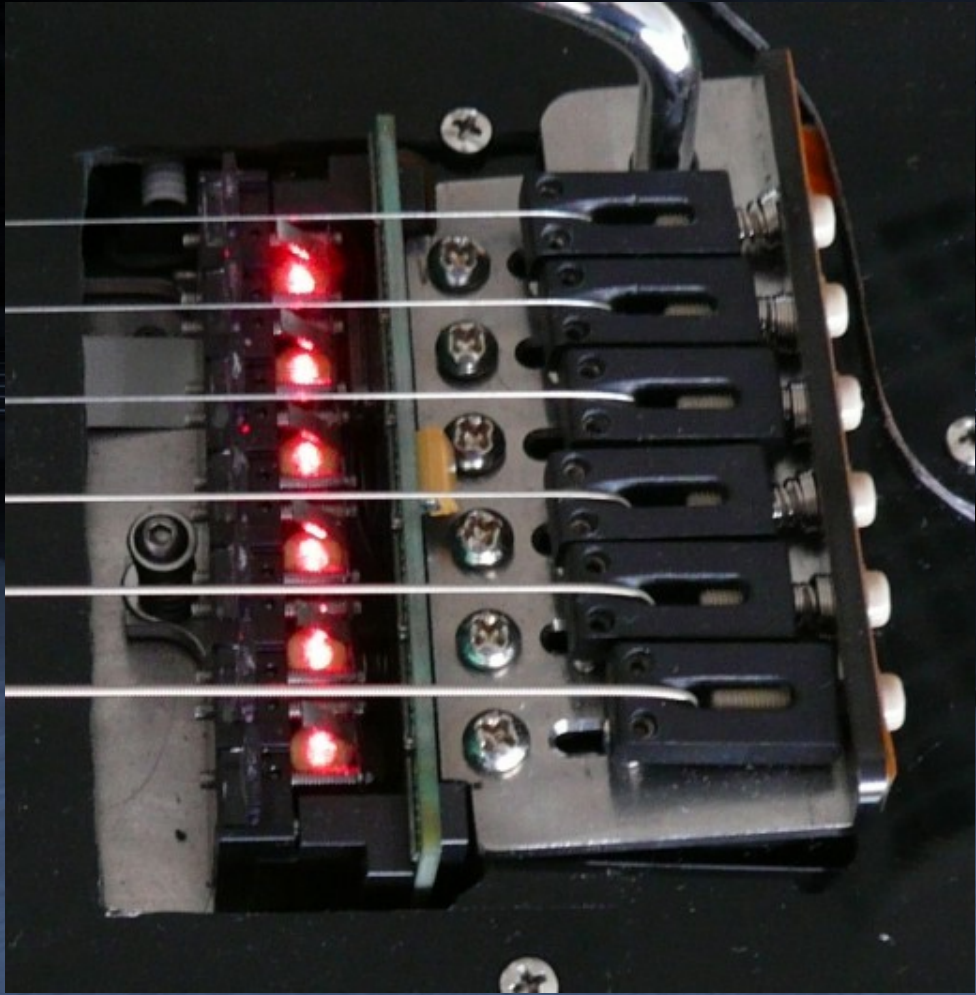

Hardware
Neck
Body
Electronics

- Active
- Passive
- Pickups
- Types

Magnetic

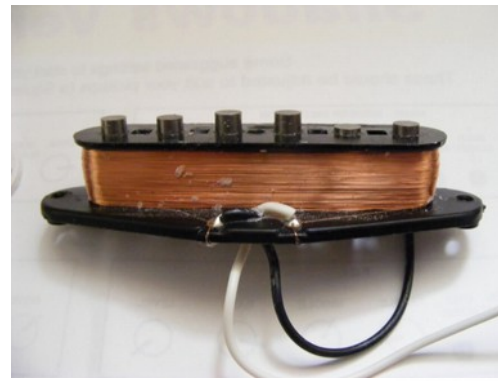

Hardware

Neck

Body

Electronics

- Active
- Passive
- Pickups
- Types
- Shell

Shell

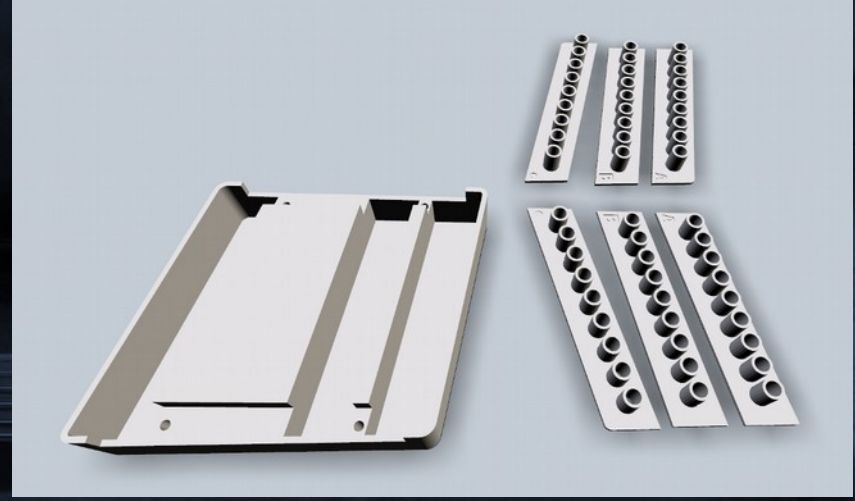
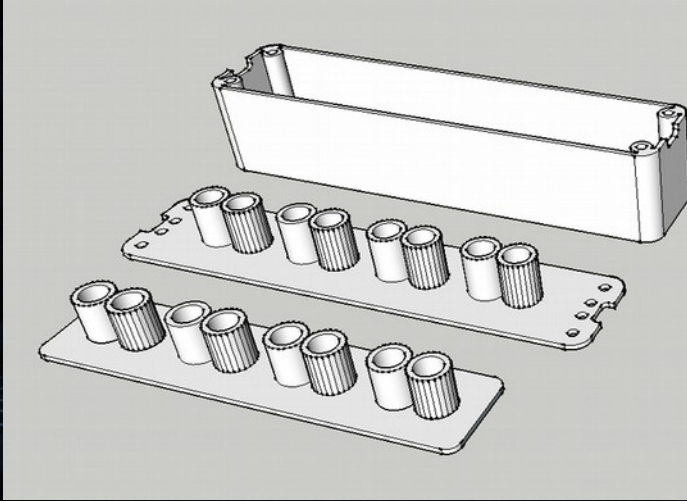

Hardware

Neck

Body

Electronics

- Active
- Passive
- Pickups
- Types
- Shell
- **Winding**

Winding



Hardware
Neck
Body

Electronics

- Active
- Passive
- Pickups
- Types
- Shell
- **Winding**

Winding



Hardware

Neck

Body

Electronics

- Active
- Passive
- Pickups
- Types
- Shell
- **Winding**

Winding

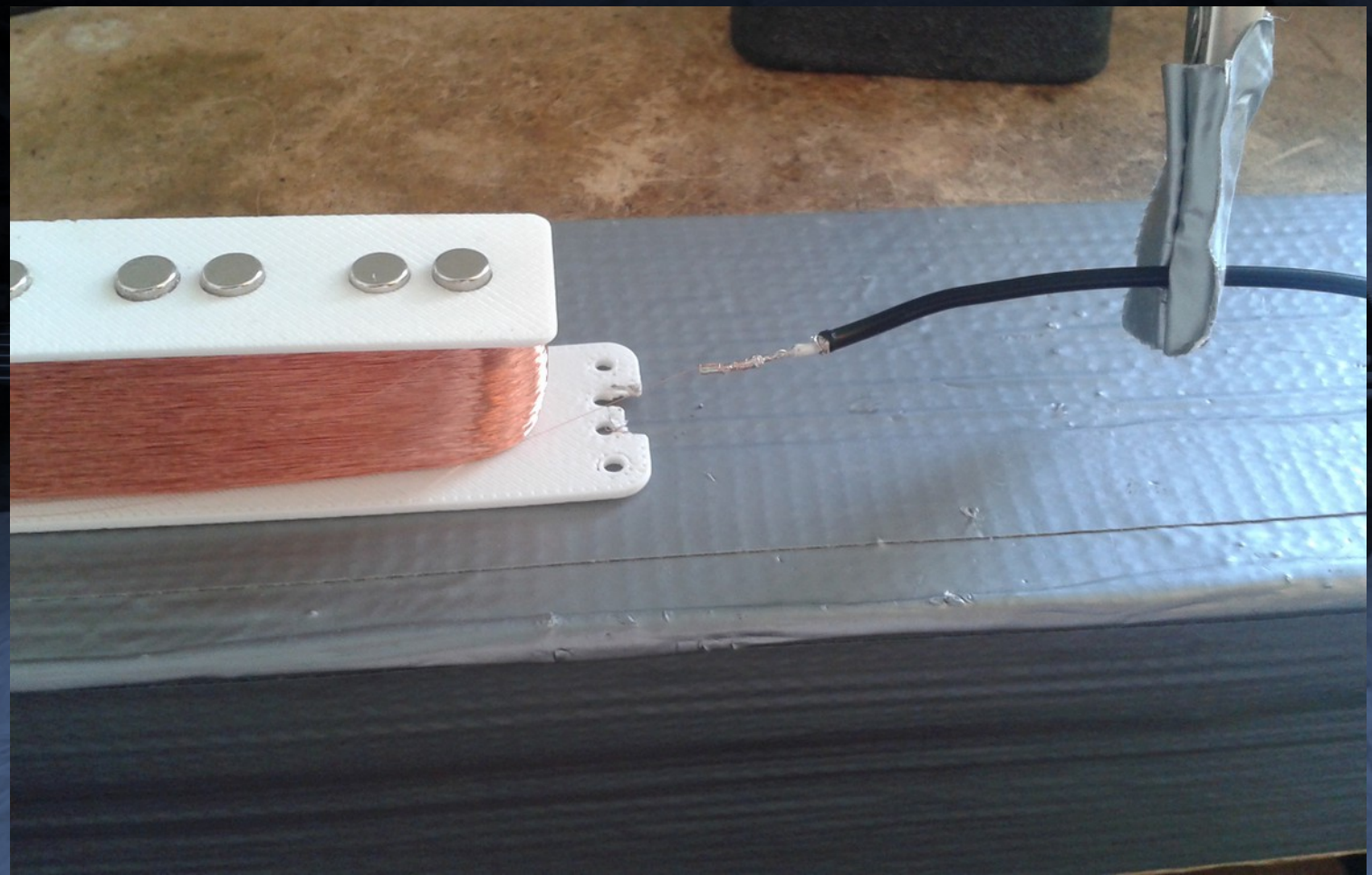

Hardware
Neck
Body
Electronics

- Active
- Passive
- Pickups
- Types
- Shell
- Winding
- Potting

Potting

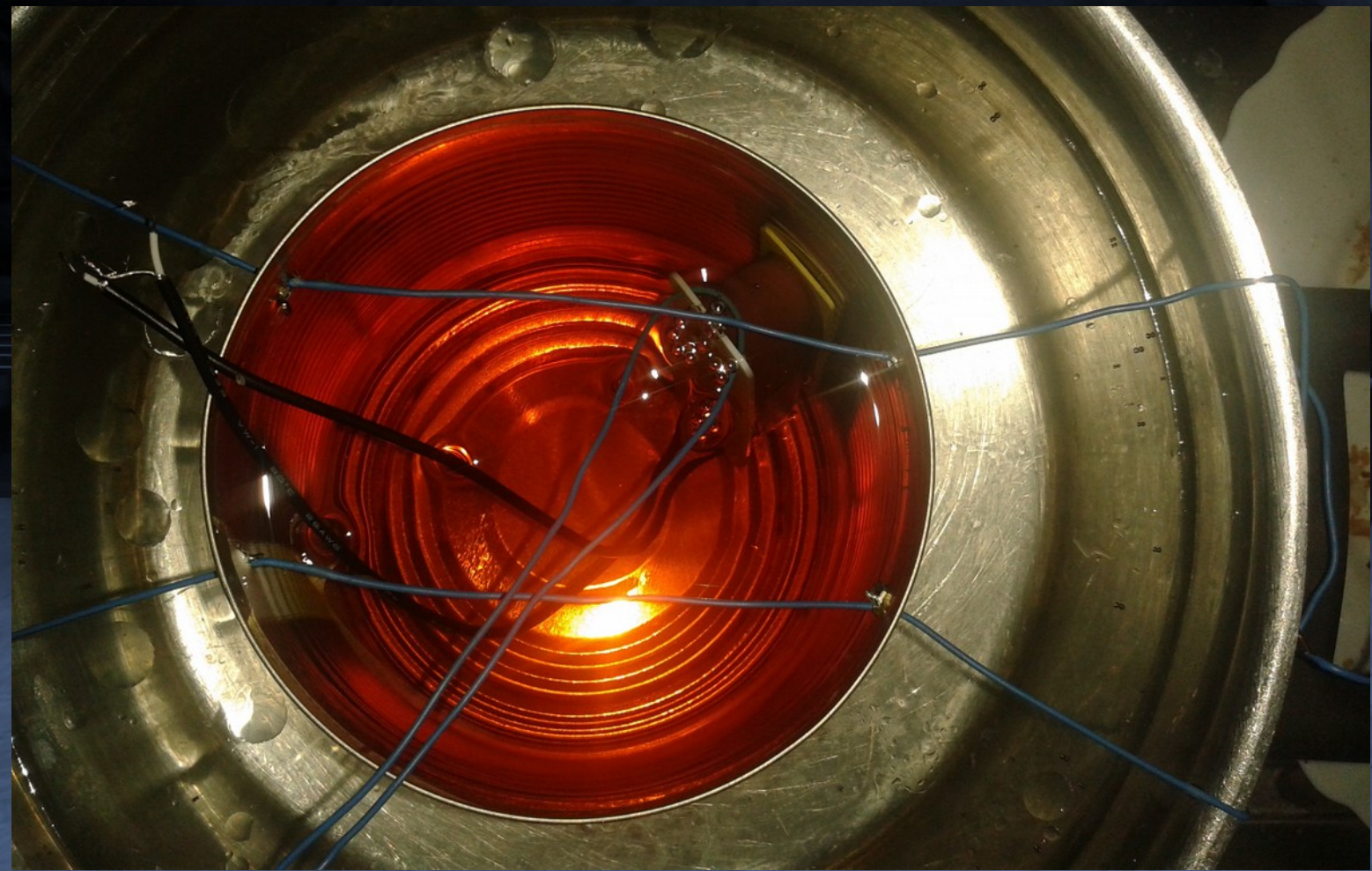

- Active
- Passive
- Pickups
- Types
- Shell
- Winding
- Potting
- Measurement

Measurement

Inductance

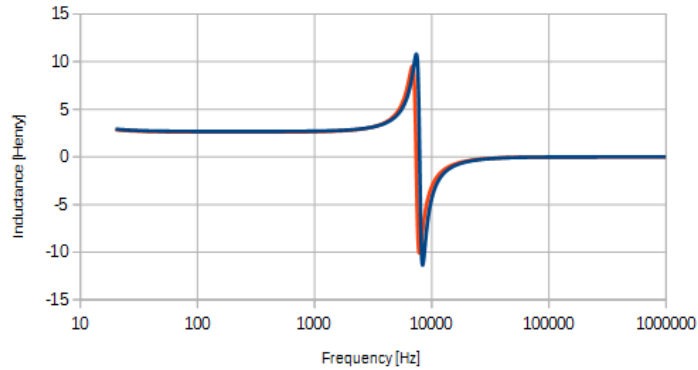

Impedance

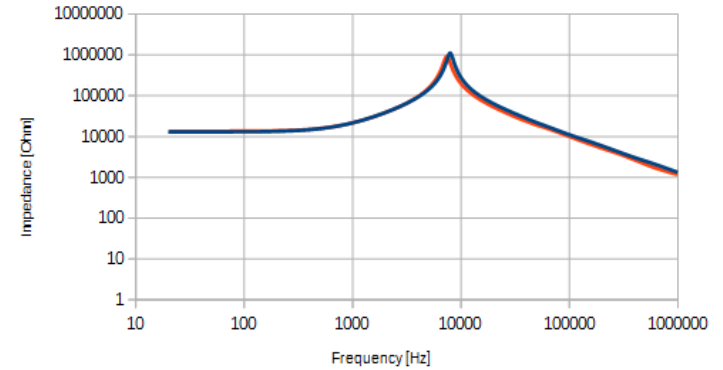

Phase Angle

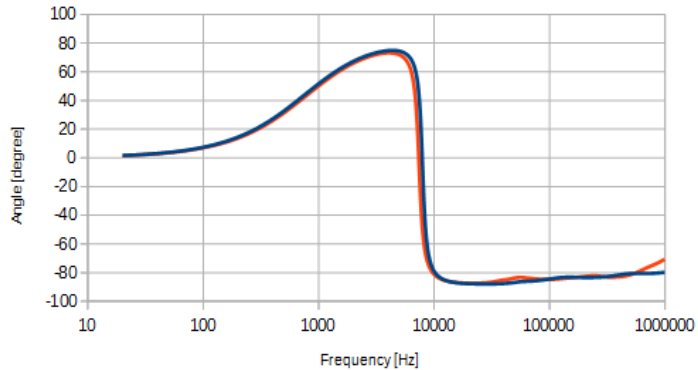

Q-Factor

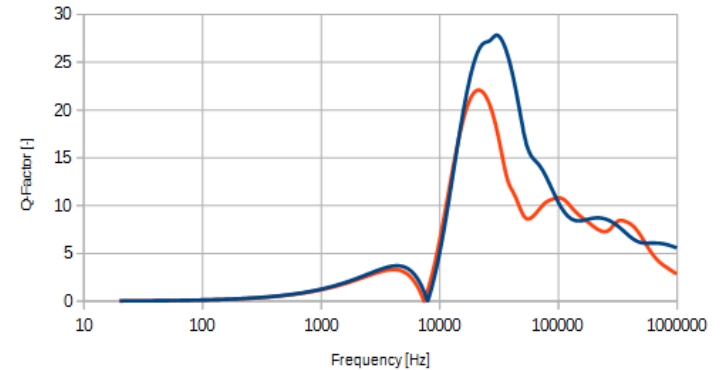

13,2 kOhm 8,5 Henry

Hardware
Neck
Body
Electronics
Finish



**KEEP
FLYING
AND
STAY
SHINY**

Finish



Hardware
Neck
Body
Electronics
Finish
· Lacquer

Lacquer



Hardware

Neck

Body

Electronics

Finish

- Lacquer
- Custom Wax Oil

Custom Wax Oil



Hardware
Neck
Body
Electronics
Finish

- Lacquer
- Custom Wax Oil

Finished Mixture



Hardware

Neck

Body

Electronics

Finish

- Lacquer
- Custom Wax Oil
- **First Coats**

First Coats



Hardware

Neck

Body

Electronics

Finish

- Lacquer
- Custom Wax Oil
- First Coats
- 20 - 30 Coats

20 - 30 Coats



Hardware

Neck

Body

Electronics

Finish

- Lacquer
- Custom Wax Oil
- First Coats
- 20 - 30 Coats

20 - 30 Coats



Hardware
Neck
Body
Electronics
Finish
The CSB JJ 2

CSB JJ 2

- Bubinga Wings
- Walnut Burl Top
- Mahogany Neck-through
- Wenge Fingerboard



Hardware

Neck

Body

Electronics

Finish

The CSB JJ 2

CSB JJ 2

- Fretless
- Multiscale
- Headless
- Asymmetrical Neck Contour (Rounded Trapazoid)
- 10k winds of 44AWG | 10N Neo Magnets
- Bridge: Single Coil
- Neck: Humbucker

Thanks and Build More Guitars!



Arne Rick (couchsofa)

couchsofa.tumblr.com
cptrick@jabber.ccc.de
cptrick999@gmail.com

Resources

A black electric guitar is shown inside its open case, lying on a blue textured surface. The guitar is positioned horizontally, with the headstock on the left and the body on the right. The case is open, and the guitar is resting on a blue, textured fabric. The background is dark, and the overall lighting is dim, creating a moody atmosphere.

<http://www.tdpri.com/forum/tele-home-depot/>

<http://www.gitarrebassbau.de/>

<http://www.talkbass.com/forums/luthiers-corner.57/>

<https://hps.hs-regensburg.de/~elektrogitarre/>

<http://www.designholz.com/>

<http://shop.rall-online.net/>

<http://www.rockinger.com/>

<http://www.stewmac.com/>

http://www.frudua.com/guitar_craftpedia.html

<http://www.nebelheim-tonewood.de>